

GRILLE WITH
REMOVABLE
CENTRE SECTION

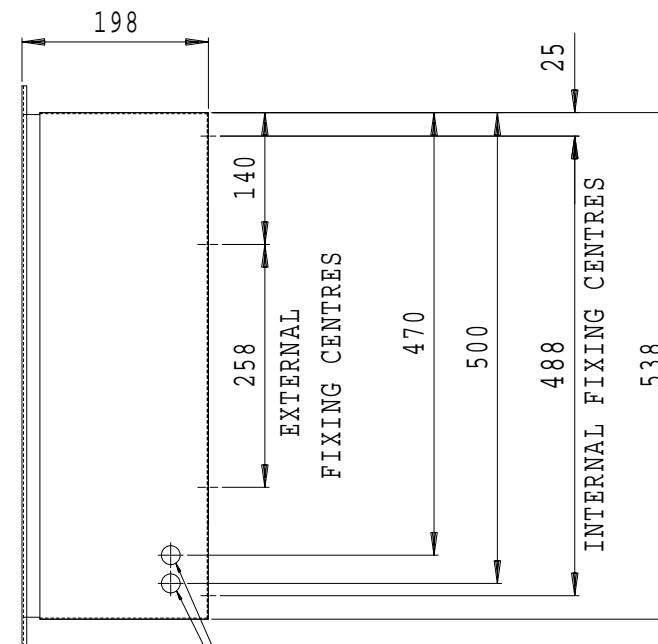

DIRECTION
OF AIRFLOW

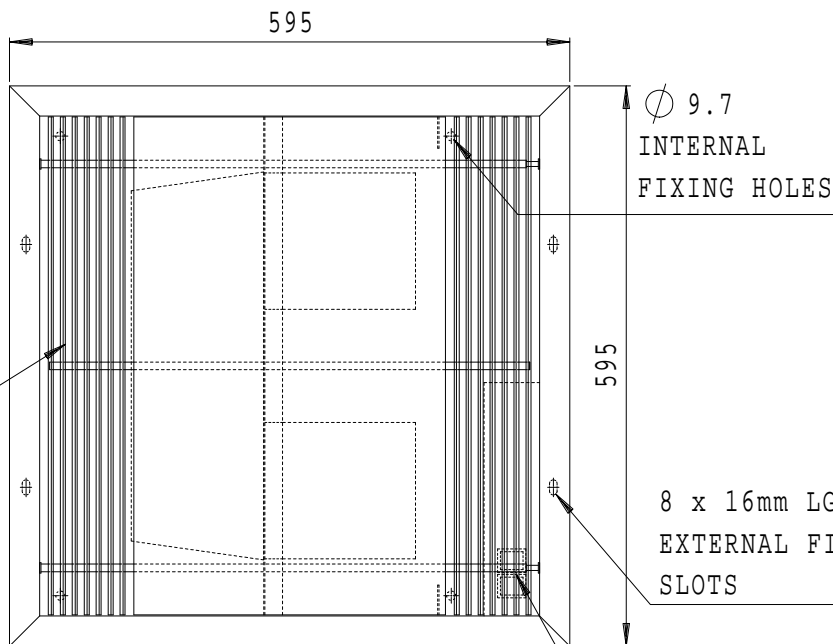
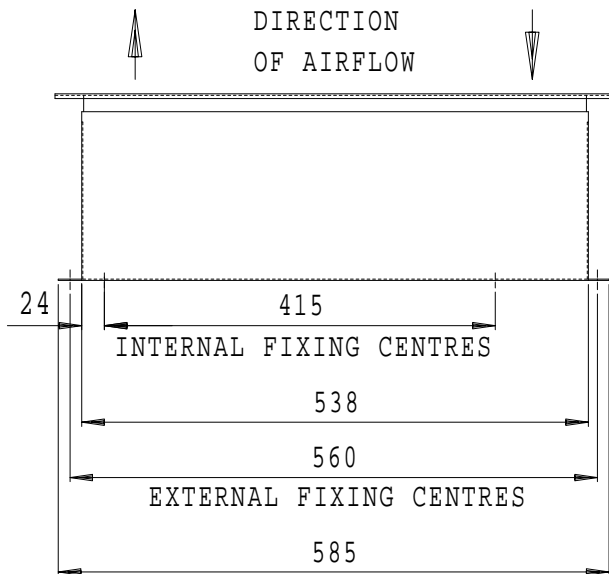

FAN ON/OFF
& SPEED
CONTROLS

CABLE ENTRY

UNIT	WEIGHT
1.5	18Kg
3.0	19Kg

NOTES:

- GENERAL TOLERANCES ON OVERALL DIMENSIONS +/- 4mm.
- PLEASE NOTE: 1.5kW UNIT HAS 1 ELEMENT & 3.0kW UNIT HAS 2.

REV.	MOD. NO.	DATE	DRN	CHKD	DRAWING TO B.S. 308:PARTS 1,2 AND 3.			DRAWING SCALE: 1:1	PRINT SCALE: N.T.S.	DRAWN	ANR	DIFFUSION ENVIRONMENTAL LTD 47 Central Avenue, West Molesey, Surrey, KT8 2QZ Telephone 020 8783-0033. Fax 020 8783-0140																																									
3	INTERNAL HOLE POS'NS ADDED	09-10-13	MW		WELDING TERMS AND SYMBOLS TO B.S. 499:PART 2.					DATE	28-10-03																																										
MODIFICATION					<table border="1"> <thead> <tr> <th colspan="4">GEOMETRIC TOLERANCE SYMBOLS</th> </tr> <tr> <th>CHARACTERISTIC</th> <th>SYM</th> <th>CHARACTERISTIC</th> <th>SYM</th> </tr> </thead> <tbody> <tr> <td>Straightness</td> <td>—</td> <td>Angularity</td> <td>∠</td> </tr> <tr> <td>Flatness</td> <td>▭</td> <td>Run out</td> <td>↗</td> </tr> <tr> <td>Roundness</td> <td>○</td> <td>Position</td> <td>⊕</td> </tr> <tr> <td>Cylindricity</td> <td>∩</td> <td>Concentricity</td> <td>⊕</td> </tr> <tr> <td>Profile of a line</td> <td>∩</td> <td>Symmetry</td> <td>⊕</td> </tr> <tr> <td>Profile of a surface</td> <td>∩</td> <td>M.M.C.</td> <td>⊕</td> </tr> <tr> <td>Parallelism</td> <td>//</td> <td>Squareness</td> <td>⊥</td> </tr> </tbody> </table>			GEOMETRIC TOLERANCE SYMBOLS				CHARACTERISTIC	SYM	CHARACTERISTIC	SYM	Straightness	—	Angularity	∠	Flatness	▭	Run out	↗	Roundness	○	Position	⊕	Cylindricity	∩	Concentricity	⊕	Profile of a line	∩	Symmetry	⊕	Profile of a surface	∩	M.M.C.	⊕	Parallelism	//	Squareness	⊥	ALL DIMENSIONS IN MM THIRD ANGLE PROJECTION			MAT'L		CHECKED	JMc	TITLE		SALES GA. CEILING TILE Mk2 1.5kW & 3kW ELECTRIC UNIT
GEOMETRIC TOLERANCE SYMBOLS																																																					
CHARACTERISTIC	SYM	CHARACTERISTIC	SYM																																																		
Straightness	—	Angularity	∠																																																		
Flatness	▭	Run out	↗																																																		
Roundness	○	Position	⊕																																																		
Cylindricity	∩	Concentricity	⊕																																																		
Profile of a line	∩	Symmetry	⊕																																																		
Profile of a surface	∩	M.M.C.	⊕																																																		
Parallelism	//	Squareness	⊥																																																		
2 MIN MOD 26-09-05 DD								FINISH		APP'D	JMc	JOB																																									
1 REQ 3252 28-10-03 ANR JMc										DATE	26-11-03	DRG.NO.	A1/16009																																								
					TOLERANCES UNLESS OTHERWISE STATED DIMENSIONAL ± 0,5 ANGULAR ± 1°																																																