

ITEM	DESCRIPTION
1	WALL MOUNTED CONTROL PANEL.
2	UNIT SUPPORT CHANNEL (2-POSITIONS).
3	CONTROL BOX.
4	CABLE ENTRY ϕ 25.0mm & 12.7mm.
5	COIL TAILS ϕ 28mm.
6	FILTER (THUMBSCREW FIXINGS).
7	INLET / DISCHARGE / UNIT ACCESS, NON-REMOVABLE HINGED CORE GRILLE, WITH QUICK RELEASE CONCEALED FASTENINGS AND SAFETY CORDS.

NOTES:

1. GENERAL TOLERANCE ON OVERALL DIMENSIONS: +/-4mm.
2. OUTER CASING FINISHED IN GALVANISED STEEL.
3. DISCHARGE GRILLE PAINTED WITH POWDERCOAT PAINT, (COLOUR SPECIFIED BY THE CUSTOMER, OR WHITE TO RAL9010 AS STANDARD).

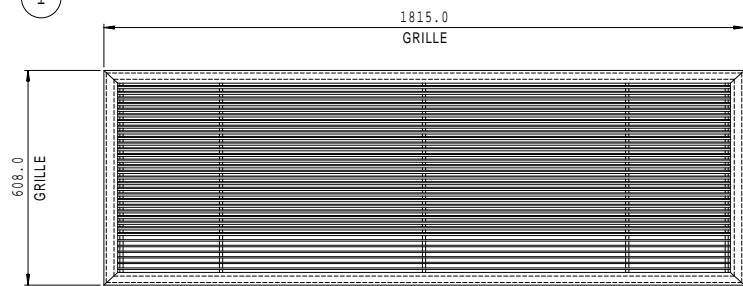
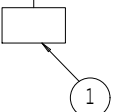
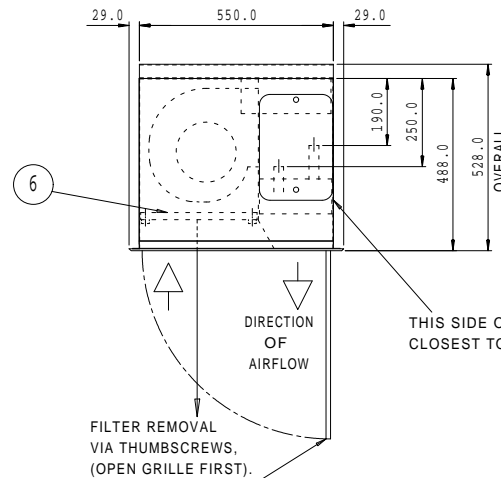
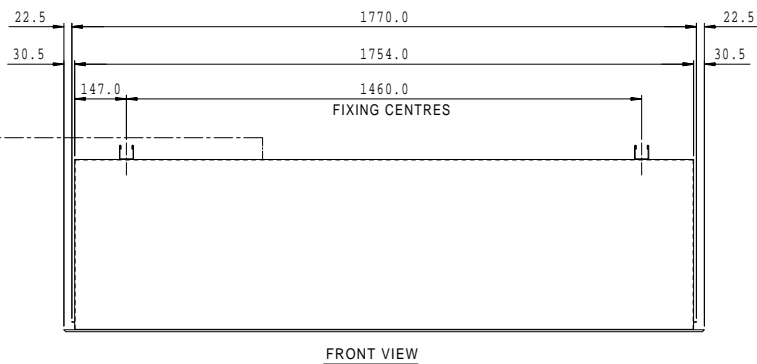

THIS SIDE OF UNIT CLOSEST TO THE DOOR.

FILTER REMOVAL VIA THUMBSCREWS, (OPEN GRILLE FIRST).

The designs shown in these drawings are the original creations of Diffusion Environmental Systems which owns all the intellectual property rights therein. No reproduction may be made of the drawings nor may articles be made therefrom without prior written permission
ALL RIGHTS RESERVED
C ET ENVIRONMENTAL LTD

REV.	MOD.NO.	DATE	DRN	CHKD	DRAWING TO B.S. 308:PARTS 1,2 AND 3.		DRG SCALE	PRINT SCALE	DRAWN	MW	DIFFUSION			
1	FIRST ISS.	22-11-11	MW		WELDING TERMS AND SYMBOLS TO B.S. 499:PART 2.		1:1	N.T.S.			47 Central Avenue, West Molesey, Surrey, KT8 2QZ Telephone 020 8783-0033. Fax 020 8783 0140 email: diffusionheat@etenv.co.uk			
MODIFICATION					GEOMETRIC TOLERANCE SYMBOLS CHARACTERISTIC SYM CHARACTERISTIC SYM Straightness — Angularity \sphericalangle Flatness \sphericalangle Run out \sphericalangle Roundness \circ Position \oplus Cylindricity \oslash Concentricity \odot Profile of a line \wedge Symmetry \equiv Profile of a surface \frown M.M.C. \ominus Parallelism \parallel Squareness \perp		ALL DIMENSIONS IN MM THIRD ANGLE PROJECTION TOLERANCES UNLESS OTHERWISE STATED DIMENSIONAL \pm 0,5 ANGULAR \pm 1°		MATERIAL		DATE 22-11-11		TITLE GENERAL ARRANGEMENT - SALES SPECIAL MIRAGE HIGH PERFORMANCE 1800 LPHW RECESSED, C/W HINGED GRILLE.	
							FINISH		CHECKED		JOB			
									DATE		DRG.NO. A1/26898			