

Article group  
1.41



07/2009  
GB

# Katherm QL



**Innovative,  
professional,  
international**

In over 37 years, Kampmann GmbH has grown from being a family-led company to become an internationally

renowned group of companies. Kampmann systems for heating, cooling and ventilation are today market leaders in a number of different market sectors. Innovation and the highest standards of quality guarantee this success into the future.

We have an "ear on the market" and the knowledge and expertise gained from 35 years of experience in development, production and sales. This, combined with a professionally-manned research and development department, is the basis for our continuous product development. This is what allows us to provide our customers with the best technical product at any time.

Traditionally, Kampmann's skills and expertise have been in the production of standard products with an extraordinary range of adapted products, as well as in the production of technically and visually high-quality tailor-made design solutions. Our specialist staff deal with the building in its entirety and develop unique and efficient system solutions. Our entire range is reflected in mix of standard, non-standard and tailor-made products for project-orientated solutions.

We set ourselves very high standards in production. Today an exceptionally well-trained specialist workforce manufactures high-quality Kampmann products in three plants for customers throughout the world. A number of different certificates are evidence of our high standards of quality, which have become the standard at Kampmann. Our products are characterised by the high guaranteed DIN EN-tested heat outputs. In terms of quality management the requirements of TÜV certification according to DIN EN ISO 9001 have been met since 1996.

For decades, Kampmann customers have valued our excellent service. Local external engineers and technicians, in-house measuring engineers and the Kampmann customer service team are available to customers. Kampmann good air quality is now to be found across the globe. Our sales engineers now cover the whole of Germany and Europe.

This **Katherm QL** brochure provides you with an insight into our wide product range. Take a look and make up your own mind – do not hesitate to arrange a personal visit with us. It is our aim to meet your high quality expectations, right down to the last detail.

Well-being is our product – Quality is our benchmark!



**Hendrik Kampmann**  
Managing Director





**Peter Kaß**  
Managing Director



**Katherm QL**  
**Production in the Kampmann**  
**Lingen plant**  
Friedrich-Ebert-Straße 128-130  
49811 Lingen (Ems)  
Tel. +49 591 7108-0  
Fax +49 591 7108-300

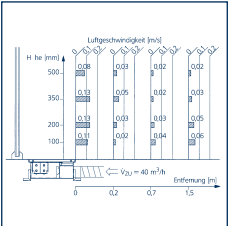
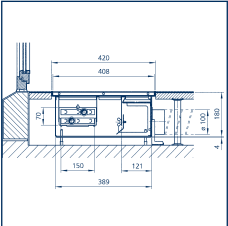

## Table of Contents Article group 1.41 Katherm QL

	<p><b>Product description/Accessories</b></p> <p>Product description ..... 4</p> <p>Overview of types.....5</p> <p>Product overview ..... 6</p> <p><b>Katherm QL engineering - an overview.</b>.....7</p> <p>The benefits .....8</p>	Product description
	<p><b>Design information</b></p> <p>Conversion to other water temperatures · Air velocity ..... 9</p>	Design information
	<p><b>Technical data</b></p> <p>Convector depth 100 mm ..... 10</p> <p>Convector depth 150 mm ..... 11</p>	Technical data
	<p><b>Specifications</b></p> <p><b>Katherm QL</b> .....12</p> <p>Your KAMPMANN contact .....13</p>	Specifications

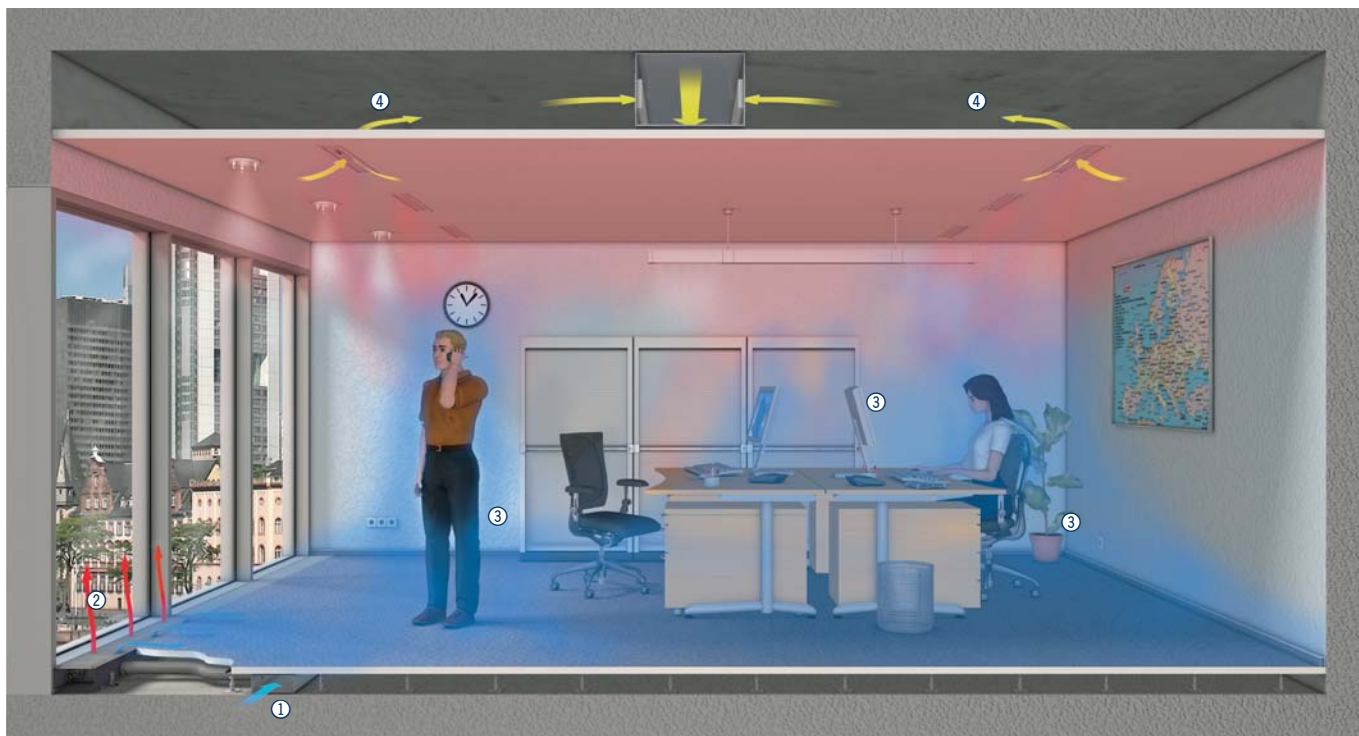

① Fresh, cool supply air enters through the displacement ventilation duct.

② Heated air rises and screens the window.

③ The fresh air rises by thermal up-currents on heat sources (people, equipment).

④ Used air is extracted.

### Katherm QL - Comfortable heating and ventilation from a floor duct system

“Heavy air” pollutes. Pleasant temperatures and unpolluted air free from harmful substances have a positive effect on a person’s well-being, as proved by scientific studies..

The Kampmann Katherm QL heating and ventilation system provides rooms with an effective and evenly-distributed supply of heat and fresh air. The high-output convector effectively screens the falling cold air.

Displacement ventilation outlets are an excellent solution for the targeted supply of prepared air. They comply with the latest knowledge with regard to low-turbulence room ventilation and permit the supply of fresh air through large air outlets in the floor. In this way the leaving air velocity and temperature can be kept very low in order to guarantee an adequate level of comfort.

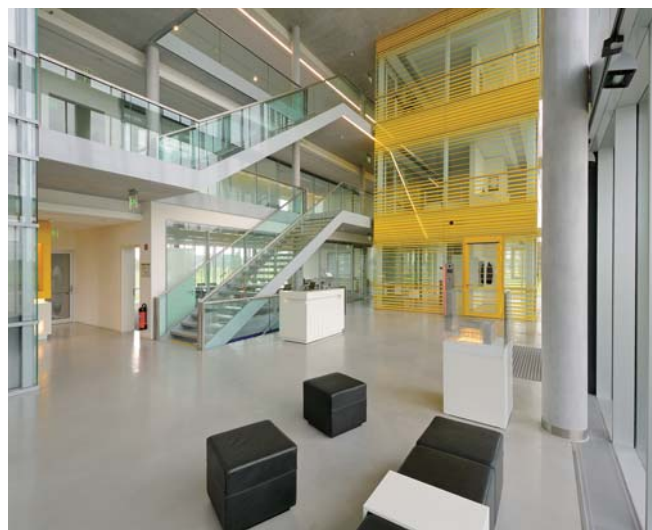

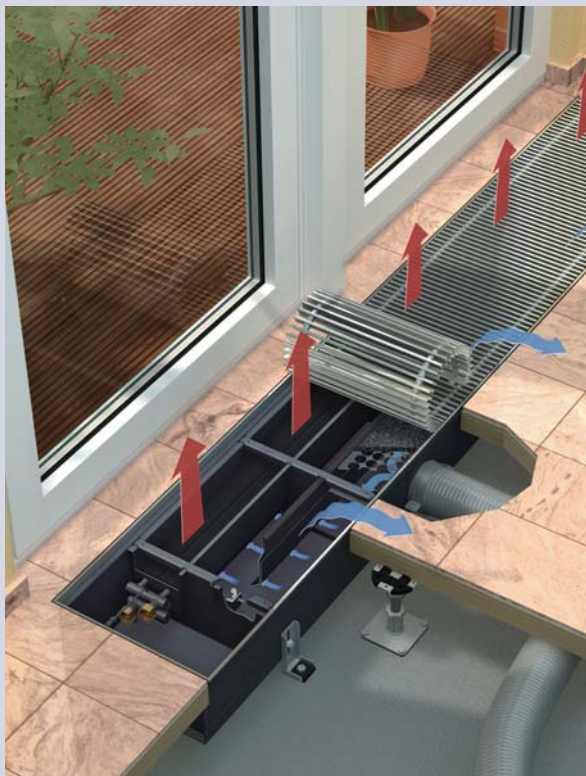

**Katherm QL – Displacement ventilation system**

1 4 1 0 4 13 1 11 00 **Type key (example)**

Article group

Enter a 0 for unallocated positions

Grille finish (cf. diagram to right)

- 1 = Roll-up grille
- 3 = Linear grille

Floor duct height

- 13 = Duct height 130 mm
- 18 = Duct height 180 mm
- 23 = Duct height 230 mm

Overall frame width

- 4 = Overall frame width 272 mm
- 5 = Overall frame width 310 mm
- 6 = Overall frame width 340 mm
- 8 = Overall frame width 400 mm
- 9 = Overall frame width 420 mm

Please state floor duct length  
(minimum length 1100 mm)

**Grille finishes**

11 = Aluminium, natural anodised

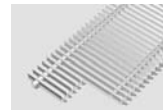

12 = Aluminium, brass anodised

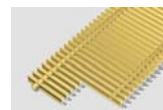

13 = Aluminium, bronze anodised

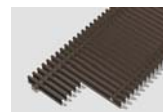

14 = Aluminium, black anodised



15 = Aluminium, bronze effect



16 = Aluminium, basalt grey painted, DB 703



31 = Stainless steel



32 = Stainless steel, polished



33 = Natural brass, CuZn 44



Other grille finishes (colours) on request

The grilles are illustrated here using a four-colour printing process and therefore do not precisely reflect the original colour.

Product description

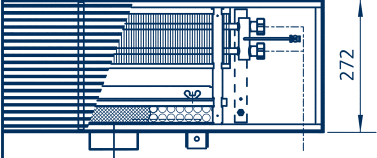
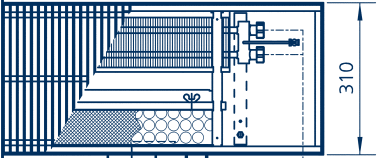
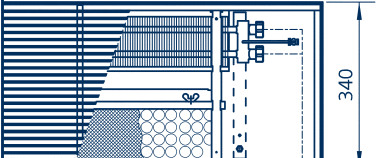
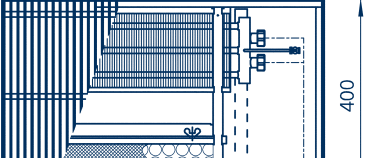
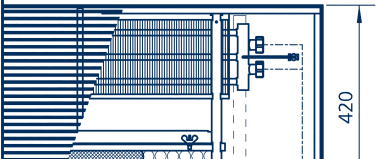
Description	Designation	Duct width	Duct length	Duct height	Max. supply air volume	Heat output <sup>1)</sup>			Dimensions
	<b>Katherm QL 272</b>	272 mm	Non-standard floor duct lengths available above 1100 mm	130 mm 180 mm 230 mm	35 $\frac{m^3}{h}$ m				
	<b>Katherm QL 310</b>	310 mm	Non-standard floor duct lengths available above 1100 mm	130 mm 180 mm 230 mm	50 $\frac{m^3}{h}$ m	LPHW 82/71°C $t_{L1} = 20^\circ\text{C}$ : 436-630 W/m (convector height 100mm)	LPHW 75/65°C $t_{L1} = 20^\circ\text{C}$ : 381-519 W/m (convector height 100mm)	LPHW 55/45°C $t_{L1} = 20^\circ\text{C}$ : 169-230 W/m (convector height 100mm)	see p 10
	<b>Katherm QL 340</b>	340 mm	Non-standard floor duct lengths available above 1100 mm	130 mm 180 mm 230 mm	60 $\frac{m^3}{h}$ m				
	<b>Katherm QL 400</b>	400 mm	Non-standard floor duct lengths available above 1100 mm	130 mm 180 mm 230 mm	50 $\frac{m^3}{h}$ m	LPHW 82/71°C $t_{L1} = 20^\circ\text{C}$ : 698-911 W/m (convector height 100mm)	LPHW 75/65°C $t_{L1} = 20^\circ\text{C}$ : 573-801 W/m (convector height 100mm)	LPHW 55/45°C $t_{L1} = 20^\circ\text{C}$ : 282-394 W/m (convector height 100mm)	see p 11
	<b>Katherm QL 420</b>	420 mm	Non-standard floor duct lengths available above 1100 mm	130 mm 180 mm 230 mm	60 $\frac{m^3}{h}$ m				

<sup>1)</sup>Heat output without supply air volume per metre of finned convector

#### Katherm QL – Displacement ventilation air from the floor

Displacement air is supplied to the displacement ventilation unit in cooling mode at 2 to 4 K below the room temperature and is blown into the room at an air velocity of well below 0.3 m/s. All of the supply units can be accommodated within the raised floor (above a height of 140 mm) or are supplied from the floor underneath. The height of the system can be adapted to the construction of the raised floor.

The air inlets and outlets are arranged in such a way that the warm air from the Kampmann high-output convector and also the colder air from the displacement air outlet flows out in a controlled and targeted manner, thus ensuring thermal comfort.

#### Katherm QL, Function

The prepared cool air emerges from the floor duct into the room and spreads out as a stable layer at floor level. The fresh air rises from this "pool of cold air" by means of natural thermal currents up heat sources, such as people or electrical equipment. A low-turbulence exchange of air is produced and a supply of pleasant cooled air is guaranteed.

The leaving velocity and temperature of the air can thus be kept very low. At the same time, room air passes through the convector and is warmed. The emerging warm air mixes with the cool air in front of the glazing, preventing a fall in temperature at the window.

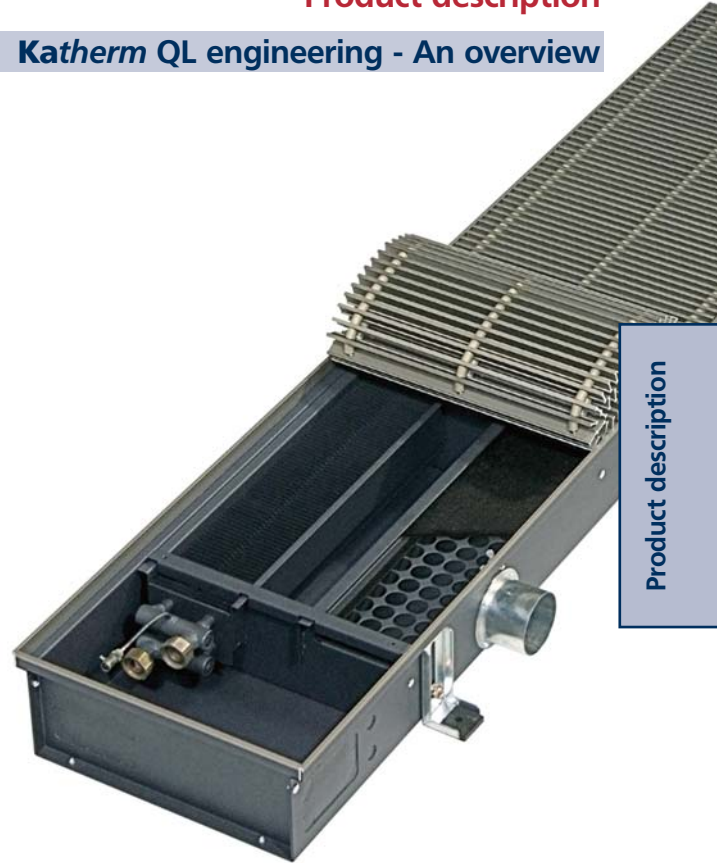

Product description

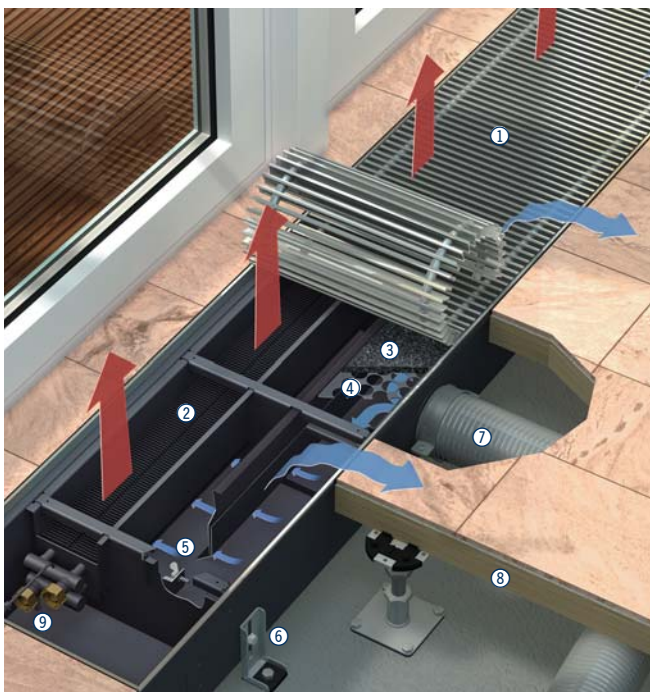

- |                                      |                          |
|--------------------------------------|--------------------------|
| ① Kampmann "optiline" roll-up grille | ⑥ Height adjustment feet |
| ② High-output convector              | ⑦ Flexible pipe          |
| ③ G2 (EU2) filter                    | ⑧ Raised floor           |
| ④ Perforated plate                   | ⑨ Heating connection     |
| ⑤ Perforated sliding plate           |                          |

#### Katherm QL engineering - An overview

- Floor duct made of sendzimir galvanised sheet steel, painted graphite grey on both sides
- Floor duct height 130, 180 und 230 mm, minimum installed height of 140 mm; further dimensions on request
- Overall frame width 272, 310, 340, 400 and 420 mm; intermediate dimensions on request
- Minimal floor duct length 1100 mm
- Brackets positioned at regular intervals along the floor duct to provide reinforcement
- Special mounting feet for 0-100% height adjustment
- High-output cu/al convectors - 100 and 150 mm in depth
- Water connection 1/2" room-side, displacement ventilation connection Ø 70 mm or 100 mm room-side
- G2 (EU2) filter, combined with a perforated panel, guarantees an even supply of air. The outlet pulse has disappeared at a distance of only 500 mm from the air outlet.
- Additional perforated sliding panel between displacement ventilation outlet and convector, which increases the heat output in problem areas.
- No draughts as air velocity is well below 0.3 m/sec
- Made-to-measure, easy to install., even when units incorporate mitred corners, recesses, curves etc.
- Cover provided by attractive "optiline" roll-up grille.



### Kampmann Katherm as a displacement ventilation system offers a number of benefits:

- Displacement ventilation provides a comfortable room climate.
- Cold air in front of large expanses of glazing is effectively screened.
- The air velocity is max. 0.3 m/sec.
- The room can be arranged independently of the heating system.
- The overall appearance of the building is not impaired.
- There is no need for heaters fitted to mullions - thus making maximum use of the space available.
- All of the services can be accommodated within the raised floor.

#### Technical air volume/heating tests

Katherm QL was developed in close collaboration with consulting engineers and architects and since this time many projects have been completed using Katherm QL in a number of different models. The HVAC (HLK) at the University of Stuttgart conducted extensive measurements and performance tests to ensure that a precise demand-led system can always be designed for each particular project.

#### Made to measure, easy to install

On request, the Kampmann service team can take site measurements and ensure, during installation, that mitred corners, curves or ducts with recesses are correctly dimensioned. This guarantees that even complicated components can be made to measure and then quickly fitted.

#### Project solutions · Non-standard models

Different requirements can be incorporated to deal with conditions on site, specific facade or floor constructions and the individual demands of clients, architects or consulting engineers to develop a bespoke project solution:

- Higher heat outputs to deal with large expanses of glazing or the absence of an additional heating system,
- Higher supply air volumes including adaptation of the displacement ventilation outlet surface,
- Wide range of grilles with an extensive selection of colours and models,
- Duct dimensions and design adapted to the floor and facade construction, e.g. raised or hollow floors, taking into consideration the:
  - Floor structure by adapting the duct height and provision of raised floor mounting brackets
  - Building grid with sound-attenuated partition walls for variable room partitioning
  - Floor/facade grid including adaptation of the fitting options.



Conversion to other water temperatures · Air velocity

Conversion to other water temperatures

Providing the intended water temperatures are not listed in the technical data tables, they can be calculated as follows:

Calculation formulae

$$\Delta t = \frac{t_{w1} + t_{w2}}{2} - t_L \quad (1)$$

$$f = \left[ \frac{\Delta t}{50} \right]^n \quad (2)$$

$$Q = Q_n \cdot f \quad (3)$$

Abbreviations

- $t_{w1}$  [°C] = Flow temperature
- $t_{w2}$  [°C] = Return temperature
- $t_L$  [°C] = Room air temperature
- $\Delta t$  [K] = Mean excess temperature
- $\Delta t_w$  [K] = Water temperature difference
- $f$  [-] = Heat output correction factor
- $Q$  [W/m] = Heat output per m finned convector length
- $Q_n$  [W/m] = Standard heat output per m finned convector length at LPHW 75/65 °C,  $t_L = 20$  °C
- $n$  [-] = Exponent = 1.59 with convector depth 100 mm  
Exponent = 1.39 with convector depth 150 mm
- $m$  [l/h] = Water flow rate
- $r$  [Pa/m] = Water pressure per m duct length convector

$$\Delta t_w = t_{w1} - t_{w2} \quad (4)$$

$$m = \frac{Q}{\Delta t_w} \cdot 0.86 \quad (5)$$

Calculation example:

Given:

- Katherm QL 420
- Overall frame width = 420 mm
- Floor duct height = 180 mm
- Flow temperature  $t_{w1} = 65$  °C
- Return temperature  $t_{w2} = 55$  °C
- Room air temperature  $t_L = 22$  °C

Required:

- Heat output  $Q$  in W
- Water pressure  $r$  in Pa/m

Calculation:

$$\Delta t = \frac{t_{w1} + t_{w2}}{2} - t_L \quad (1) = \frac{65 + 55}{2} - 22 = 38 \text{ K}$$

$$f = \left[ \frac{\Delta t}{50} \right]^n \quad (2) = \left[ \frac{38}{50} \right]^{1.39} = 0.68$$

Determining the standard heat output  $Q_n$ :

From heat output for convector depth 150 mm,

at LPHW 75/65 °C,  $t_L = 20$  °C;  $Q_n = 687 \text{ W/m}$

$$Q = Q_n \cdot f \quad (3) = 687 \cdot 0.68 = 467 \text{ W/m}$$

$$\Delta t_w = t_{w1} - t_{w2} \quad (4) = 65 - 55 = 10 \text{ K}$$

$$m = \frac{Q}{\Delta t_w} \cdot 0.86 \quad (5) = \frac{467}{10} \cdot 0.86 = 40 \text{ l/h}$$

From pressure drop diagram: Curve 2 at  $m = 40 \text{ l/h}$ ;  $r = 11 \text{ Pa/m}$

Result:

Heat output  $Q = 467 \text{ W/m}$ ;  $r = 11 \text{ Pa/m}$

Curves	
Overall frame width	Curve no.
272; 310; 340	①
400; 420	②

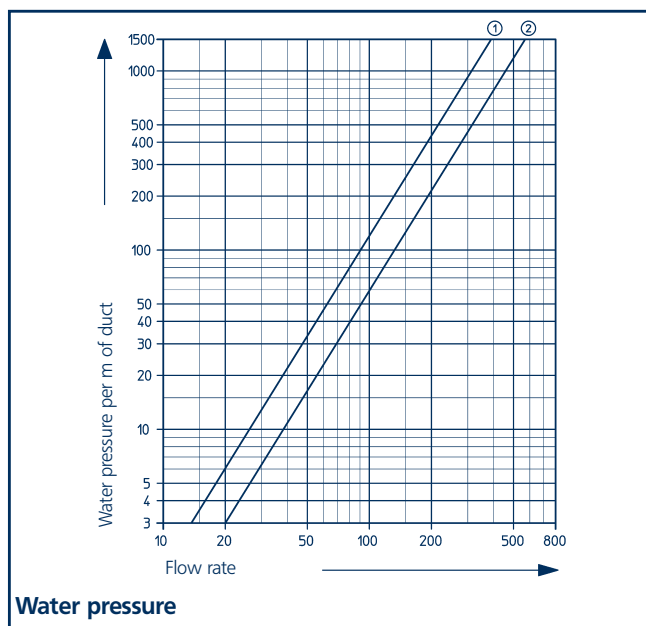

Air velocity

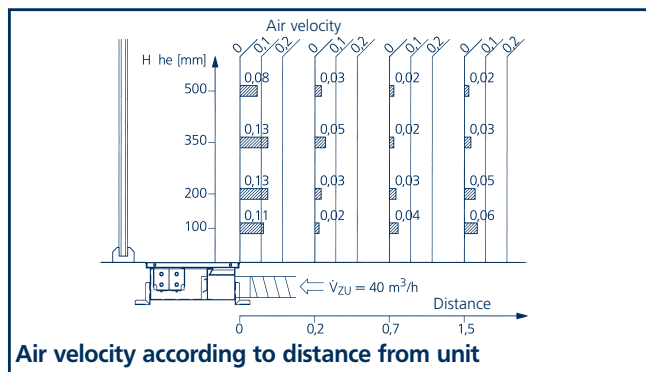

Design information

Convector depth 100 mm

Dimensions of convector depth 100 mm

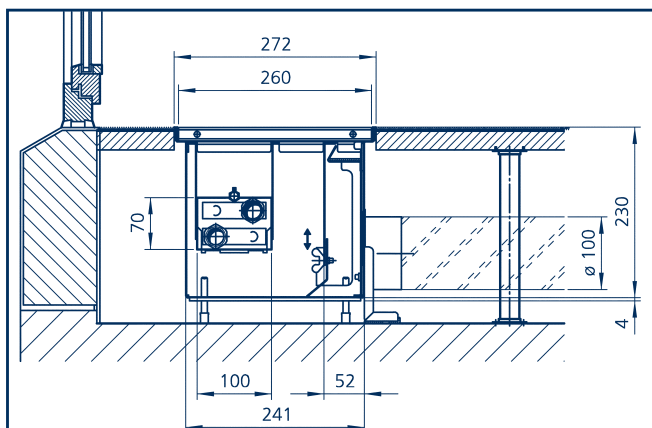

**Katherm QL 272**  
Floor duct height H = 230 mm shown

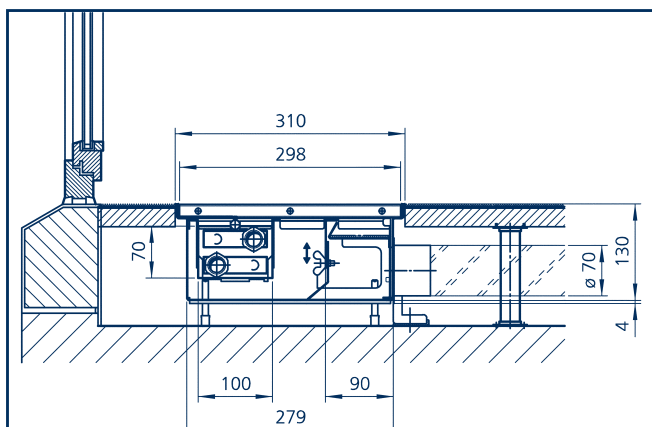

**Katherm QL 310**  
Floor duct height H = 130 mm shown

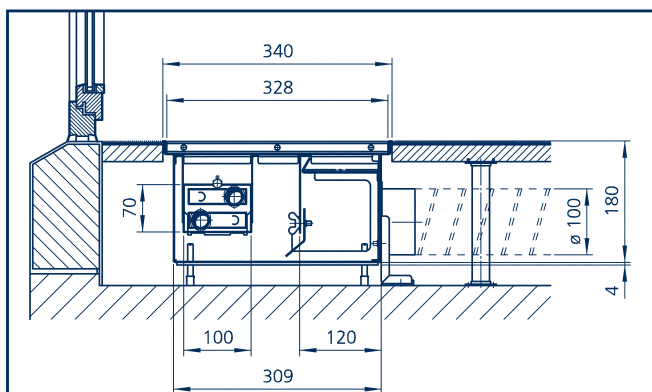

**Katherm QL 340**  
Floor duct height H = 180 mm shown

Dimensions · Supply air volume Convector depth 100 mm				
Overall frame width	[mm]	272	310	340
Floor duct width	[mm]	241	279	309
Grille width	[mm]	260	298	328
Displacement duct width	[mm]	52	90	120
Supply air volume per m max.	$V \left[ \frac{\text{m}^3/\text{h}}{\text{m}} \right]$	35	50	60
Exponent	-	1.59		

Heat output* · Convector depth 100 mm				
Floor duct height (mm)		130	180	230
Water temp.	Room air temp. °C	Heat output per m finned convector length in W/m		
LPWW 50/40 °C	20	143	182	195
	22	127	161	172
		111	141	151
LPWW 55/45 °C	18	187	239	255
	20	169	216	230
	22	152	193	206
LPHW 70/55 °C	18	317	404	431
	20	294	375	401
	22	273	348	371
LPHW 75/65 °C	18	406	517	552
	20	381	486	519
	22	357	455	486
LPHW 82/71 °C	18	489	624	666
	20	463	590	630
	22	436	557	595
LPHW 90/70 °C	20	509	649	694

Technical data

Convector depth 150 mm

Dimensions for convector depth 150 mm

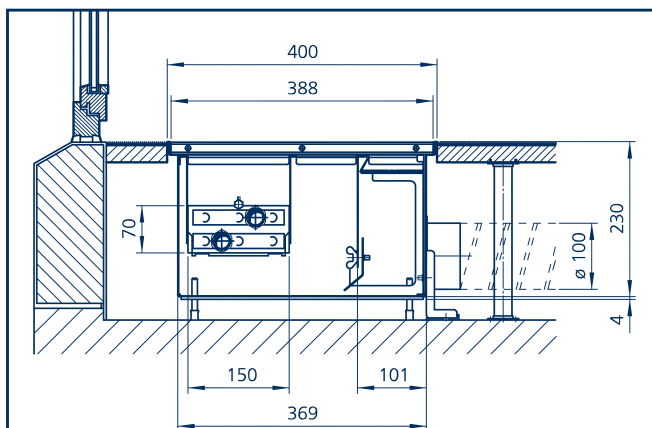

**Katherm QL 400**  
Floor duct height H = 230 mm shown

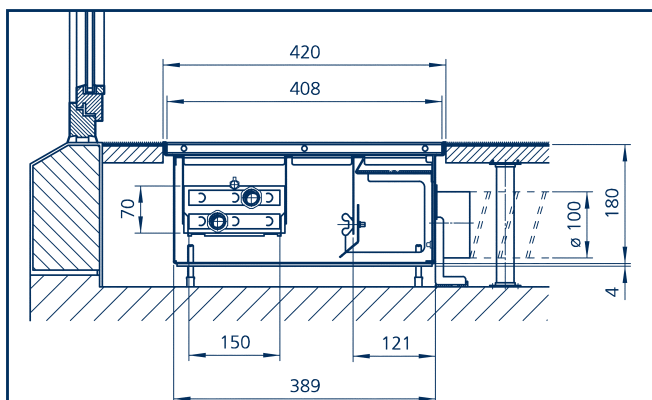

**Katherm QL 420**  
Floor duct height H = 180 mm shown

Dimensions · Supply air volume  
Convector depth 150 mm

Overall frame width	[mm]	400	420
Floor duct width	[mm]	369	389
Grille width	[mm]	388	408
Displacement duct width	[mm]	101	121
Supply air volume per m max.	$V \left[ \frac{\text{m}^3/\text{h}}{\text{m}} \right]$	50	60
Exponent	-	1.39	

Heat output\* · Convector depth 150 mm

Floor duct height (mm)		130	180	230
Water temp.	Room air temp. °C	Heat output per m finned convector length in W/m		
LPWW 50/40 °C	18	243	292	340
	20	219	262	306
	22	195	233	272
LPWW 55/45 °C	18	308	369	431
	20	282	338	394
	22	256	307	358
LPHW 70/55 °C	18	487	584	681
	20	457	548	639
	22	428	513	598
LPHW 75/65 °C	18	605	725	846
	20	573	687	801
	22	541	649	757
LPHW 82/71 °C	18	733	855	957
	20	698	814	911
	22	664	774	867
LPWW 90/70 °C	20	738	885	1032

Technical data

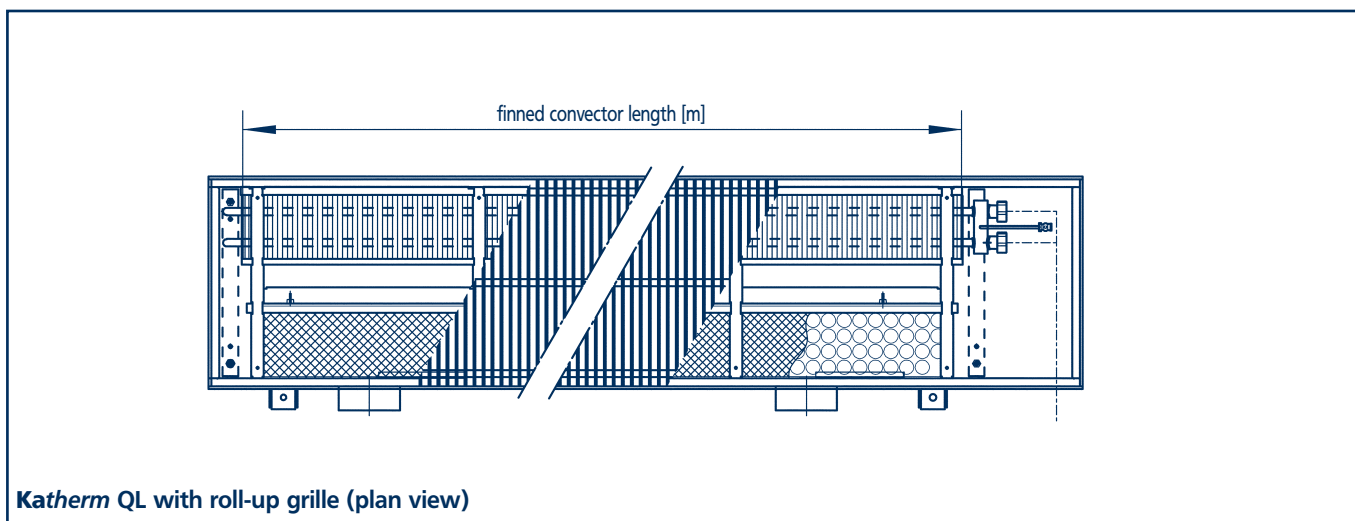

**Katherm QL with roll-up grille (plan view)**

Qty.	Article no.	Description	Price/each	Total price
m	141 0 4 13 1 11 00	<p><b>Katherm QL Floor duct heating system</b>                      delivered as a ready-to-install floor convector heating duct with supply air connection for displacement air, comprising: floor duct made of sendzimir galvanised sheet steel, painted graphite grey on both sides, with adjustment feet inside and on the side of the duct for height adjustment within raised floors; with adjustable mounting feet, fitted to the side of the duct with sound insulation; convector consisting of copper hollow pipes with aluminium fins, painted graphite grey, suitable for a maximum continuous operating pressure of 10 bar and 120 °C, sitting on sheet steel brackets with felt underlay, with additional brackets to reinforce the floor duct; with supply air spigots along the side of the duct with a slider to regulate the air volume; displacement ventilation outlet with perforated metal cover and filter for an even distribution of air;                      grille frame profile, to match the colour of the grille, consisting of a double-T profile, bar dimensions 18 x 5 mm, bar spacing 9 mm; joined by means of corrosion-proof steel springs, with matching distance spacers, free area approx. 65 %</p> <p>Complete with:</p> <ul style="list-style-type: none"> <li>1 Roll-up grille</li> <li>3 Linear grille</li> <li>11 Aluminium, natural anodised</li> <li>12 Aluminium, brass anodised</li> <li>13 Aluminium, bronze anodised</li> <li>14 Aluminium, black anodised</li> <li>15 Aluminium, bronze effect</li> <li>16 Aluminium, basalt grey painted, DB 703</li> <li>31 Stainless steel</li> <li>32 Stainless steel, polished</li> <li>33 Natural brass CuZn 44</li> </ul> <p>4 <b>Katherm QL 272</b>                      Width 272 mm                      Max. supply air volume 35 m³/h per m                      Connection 1/2" room-side</p> <p>5 <b>Katherm QL 310</b>                      Width 310 mm                      Max. supply air volume 50 m³/h per m                      Connection 1/2" room-side</p> <p>6 <b>Katherm QL 340</b>                      Width 340 mm                      Max. supply air volume 60 m³/h per m                      Connection 1/2" room-side</p> <p>8 <b>Katherm QL 400</b>                      Width 400 mm                      Max. supply air volume 50 m³/h per m.                      Connection 1/2" room-side</p> <p>9 <b>Katherm QL 420</b>                      Width 420 mm                      Max. supply air volume 60 m³/h per m                      Connection 1/2" room-side</p> <p>13 Floor duct height 130 mm                      18 Floor duct height 180 mm                      23 Floor duct height 230 mm</p> <p><b>Technical data:</b>                      Diameter of supply air spigots DN _____                      Water temp. LPHW _____ / _____ °C                      Room air temperature _____ °C                      Heat output _____ W</p> <p>Article group 1.41, Manufacturer Kampmann,                      Article no. 1410-----, Type -----</p> <p>Please state required floor duct length (minimum length 1100 mm)!</p>		
	Required for complete DataNorm/EDV article no.		Further dimensions on request	Diameter of supply air spigot on request

Specifications

<b>Nord &amp; West 1</b>	<b>KAMPMANN GmbH - Niederlassung Nord &amp; West 1</b> Friedrich-Ebert-Straße 128-130 49811 Lingen (Ems)	Tel. +49 591 7108-0 Fax +49 591 7108-300	<b>Ost</b>	<b>KAMPMANN GmbH - Niederlassung Ost</b> Johann-Gutenberg-Platz 1 06773 Gräfenhainichen	Tel. +49 34953 31-3 Fax +49 34953 31-494
<b>West 2</b>	<b>KAMPMANN GmbH - Niederlassung West 2</b> Altenberger-Dom-Straße 113 51467 Bergisch Gladbach	Tel. +49 2202 98892-0 Fax +49 2202 98892-525	<b>Süd 1</b>	<b>KAMPMANN GmbH - Niederlassung Süd 1</b> Liebigstraße 13 97080 Würzburg	Tel. +49 931 98087-0 Fax +49 931 98087-536
<b>Berlin</b>	<b>KAMPMANN GmbH - Niederlassung Berlin</b> Hauptstraße 132 16547 Birkenwerder	Tel. +49 3303 5375-0 Fax +49 3303 5375-546	<b>Süd 2</b>	<b>KAMPMANN GmbH - Niederlassung Süd 2</b> Bahnhofstraße 1 82216 Maisach	Tel. +49 8141 3991-0 Fax +49 8141 3991-516

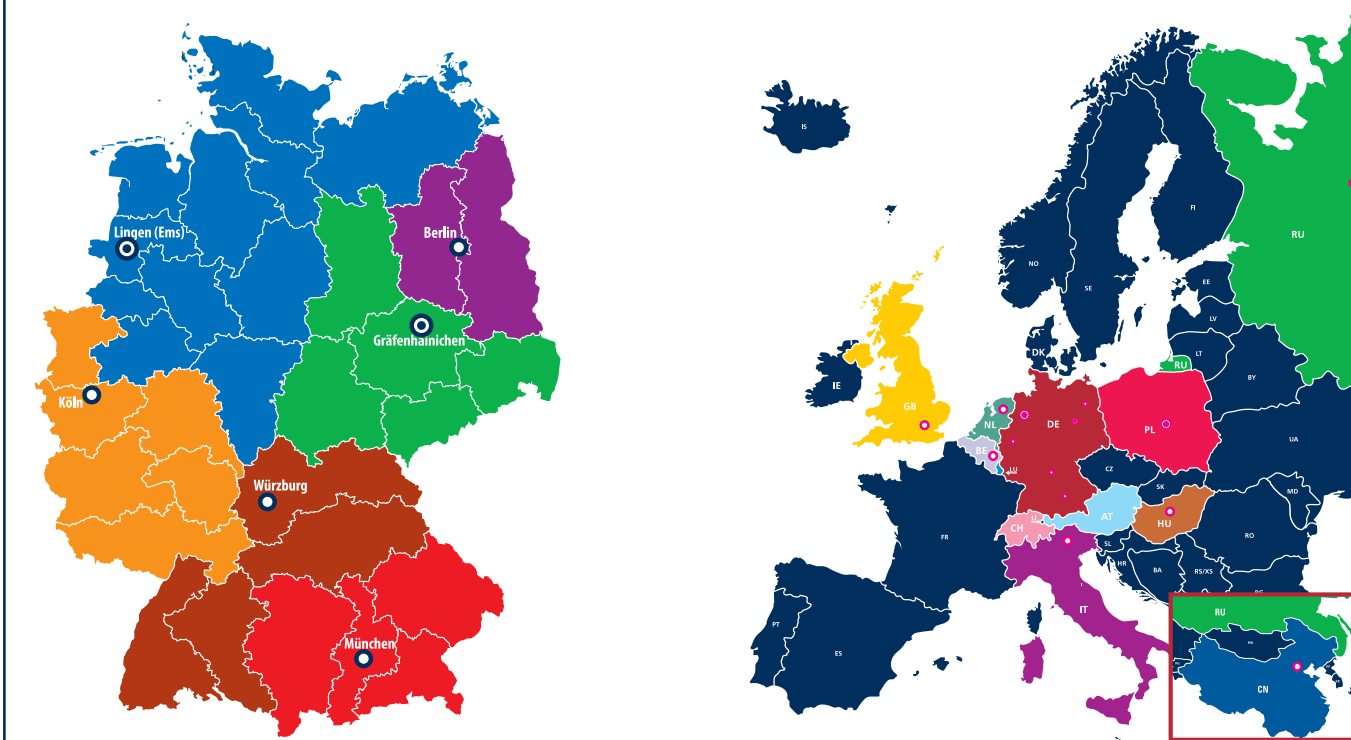

<b>AT</b>	<b>KAMPMANN GmbH - Austria Office</b> Bahnhofstraße 1 • 82216 Maisach near Munich Germany	Phone +49 8141 3991-0 Fax +49 8141 3991-516 <a href="http://www.kampmann.at">www.kampmann.at</a>	<b>IT</b>	<b>KAMPMANN GmbH - Italy Office</b> TecnoPrisma S.R.L. Via del Vigneto 19 Il piano 39100 Bolzano Italy	Phone +39 0471 930158 Fax +39 0471 513078 <a href="http://www.kampmann.it">www.kampmann.it</a>
<b>BE</b>	<b>KAMPMANN GmbH - Belgium Office</b> Godsheidestraat 1 3600 Genk Belgium	Phone +32 11 378467 Fax +32 11 378468 <a href="http://www.kampmann.be">www.kampmann.be</a>	<b>LU</b>	<b>KAMPMANN GmbH - Luxemburg Office</b> Godsheidestraat 1 3600 Genk Belgium	Phone +32 11 378467 Fax +32 11 378468 <a href="http://www.kampmann.be">www.kampmann.be</a>
<b>CH</b>	<b>KAMPMANN GmbH - Repräsentanz Schweiz</b> Tödisstraße 60 8002 Zürich Germany	Phone +41 44 2836-185 Fax +41 44 2836-186 <a href="http://www.kampmann.ch">www.kampmann.ch</a>	<b>NL</b>	<b>KAMPMANN GmbH - Netherlands Office</b> Boeierstraat 10 A 8102 H5 Raalte Netherlands	Phone +31 572 393214 Fax +31 572 382048 <a href="http://www.kampmann.nl">www.kampmann.nl</a>
<b>CN</b>	<b>KAMPMANN (Beijing) Co., Ltd.</b> Unit 1016 Landmark Tower 1 8 North Dongsanhuan Road Chaoyang District, Beijing, 100004 China	Phone +86 10 6590 6768 Fax +86 10 6590 6758 <a href="http://www.kampmann.cn">www.kampmann.cn</a>	<b>PL</b>	<b>KAMPMANN Polska Sp. z o. o.</b> ul. Lotnicza 21f 99-100 Łęczycza Poland	Phone +48 24 7219185 Fax +48 24 7219191 <a href="http://www.kampmann.pl">www.kampmann.pl</a>
<b>GB</b>	<b>KAMPMANN GmbH - UK Office</b> Dial House Govett Avenue Shepperton Middlesex TW17 8AG United Kingdom	Phone +44 1932 228592 Fax +44 1932 228949 <a href="http://www.kampmann-uk.co.uk">www.kampmann-uk.co.uk</a>	<b>PL</b>	<b>KAMPMANN Polska Sp. z o. o.</b> ul. Słowackiego 1 85-008 Bydgoszcz Poland	Phone +48 52 5836536 Fax +48 52 3406511 <a href="http://www.kampmann.pl">www.kampmann.pl</a>
<b>HU</b>	<b>KAMPMANN GmbH - Hungary Office</b> 1031 Budapest Örló u. 30 Hungary	Phone +36 1 2426830 Fax +36 1 4532416 <a href="http://www.kampmann.hu">www.kampmann.hu</a>	<b>RU</b>	<b>KAMPMANN GmbH - Representative Office Moscow</b> ul. 4 Magistralnaya dom 11 stroenie 2 123007 Moscow Russia	Phone +7 495 3630244 Fax +7 495 3630244 <a href="http://www.kampmann.ru">www.kampmann.ru</a>

**all other countries** KAMPMANN GmbH • Friedrich-Ebert-Straße 128-130 • 49811 Lingen (Ems) • Germany  
Phone +49 591 7108-660 • Fax +49 591 7108-173 • [info@kampmann.de](mailto:info@kampmann.de) • [www.kampmann.de](http://www.kampmann.de)





### EWE AG Future Centre in the Emstek ecopark

#### Product-specific information on this project

- Integration of different Katherm floor duct systems (HK, QK, QL)
- Non-Standard Katherm QL without displacement ventilation duct
- Gross volume of building 9000 m<sup>3</sup>



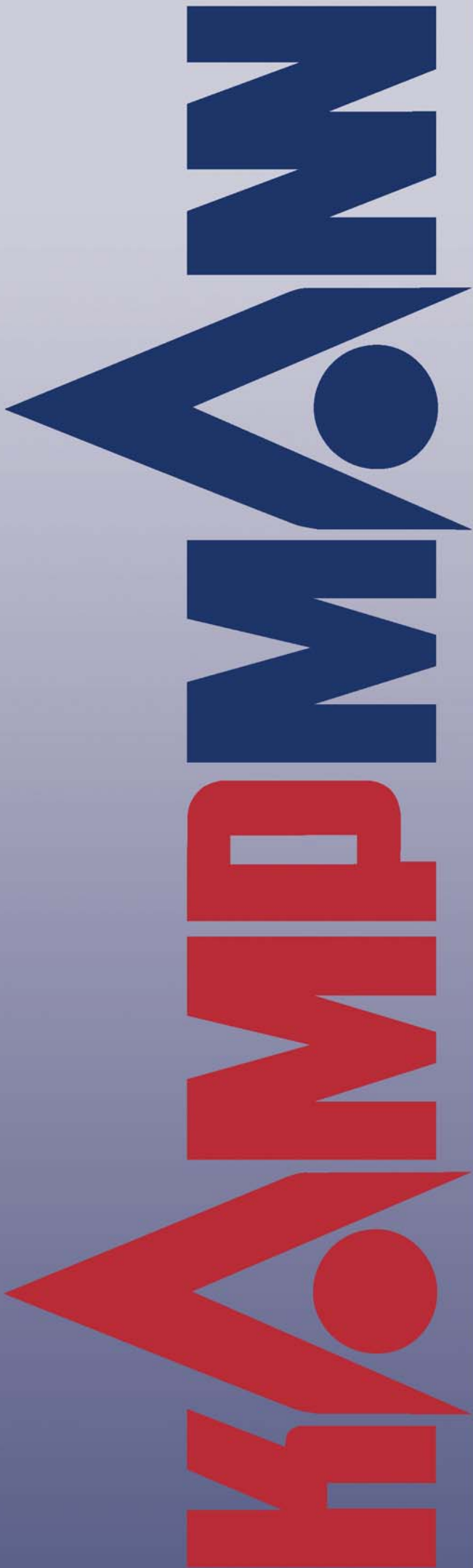

**KAMPMANN GmbH**

**UK Office**

Dial House

Govett Avenue • Shepperton, Middlesex TW17 8AG

Tel. +44 1932 228592 • Fax +44 1932 228949

info@kampmann-uk.co.uk • www.kampmann-uk.co.uk

**Keane Environmental Ltd**

Kilkenny Office • Kilcross • Inistioge • Co. Kilkenny

Tel. +353 56 7758524 • Fax +353 56 7758737

keaneenv@iol.ie • www.kampmann.de



**SYSTEMS FOR HEATING • COOLING • VENTILATING**

**KAMPMANN GMBH • Germany**

Friedrich-Ebert-Straße 128 - 130 • 49811 Lingen (Ems)

Telefon: +49 591 7108-0 • Telefax +49 591 7108-300

info@kampmann.de • www.kampmann.de