

GRILLES

Grilles Options
and Accessories

PUBLICATION

GRILLES 17

JUNE 2014

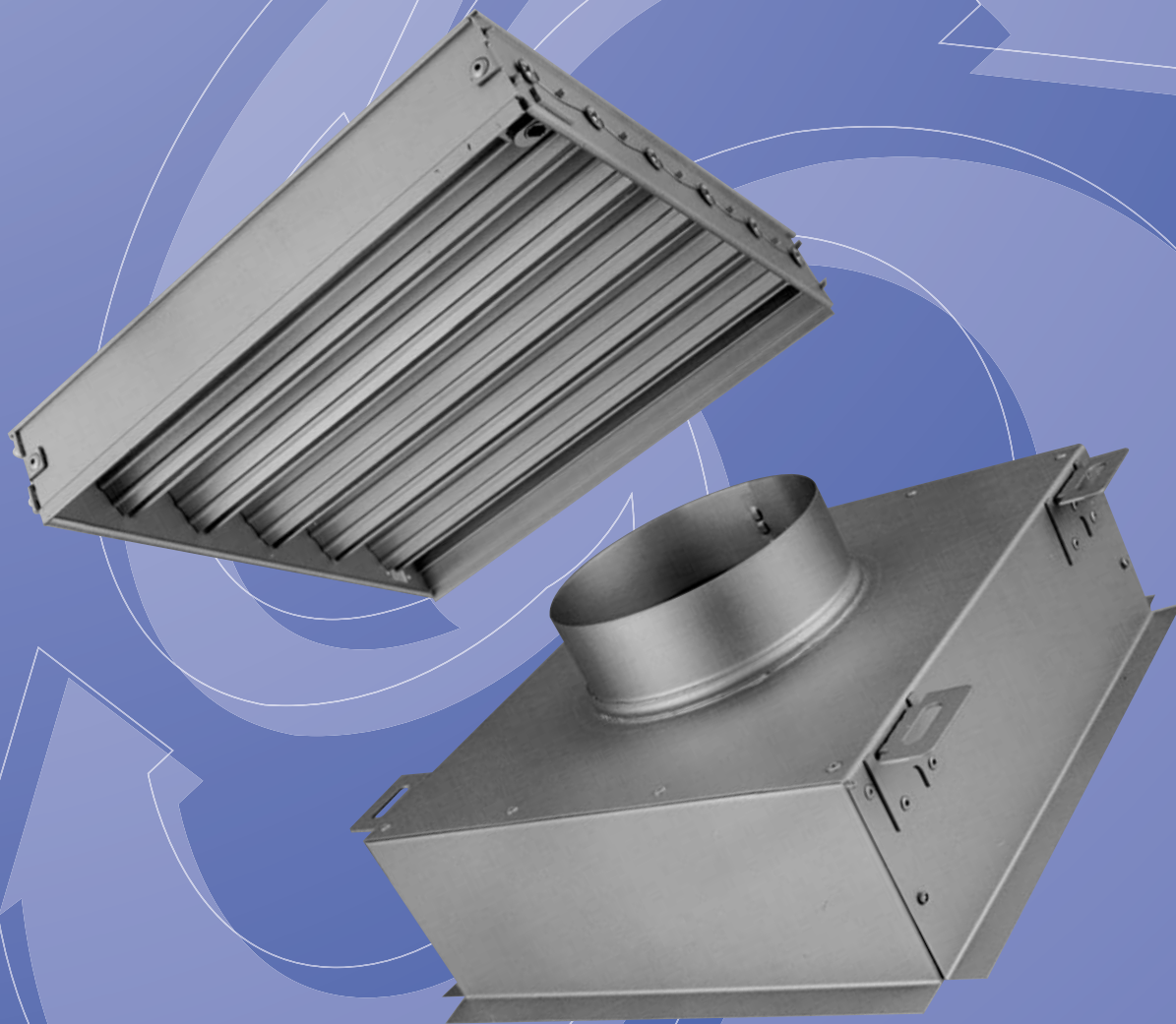

Features

- Standard and Concealed Fixings.
- Spring Clip and Quick Release Fixings.
- Screwdriver and Knob Operated Opposed Blade Dampers.
- Top and Side Entry Plenum Boxes.



GILBERTS

GRILLES

Options and Accessories

Fixing Options

This data sheet details a number of options and accessories that are available on many of our Grille Series. Please refer to specific grille data sheets for information on availability and for further dimensional details.

Flange Screw Fixing

The standard Grille Fixing is screw through the face flange using self tapping screws provided. There are a few exceptions to this rule. Please check data sheets for further information.

Standard Flange Border: 32mm wide.
Narrow 16mm border (Ref. N) Not available with screw fixing and typically uses a concealed bracket or spring clip fixing. The narrow border also reduces clearance on the aperture to as little as 7mm. Please check with office.

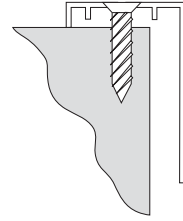

Spring Clip Fixing (Ref...SC)

Spring clip fixing offers a firm and convenient way to install grilles with the added benefit of being a concealed fixing method. By nature this method is not suitable for ceiling or sidewall mounted grilles and is recommended for cill type applications only.

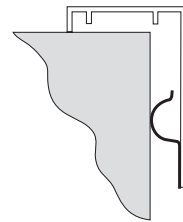

Quick Release Fixing (Ref...QR)

Quick release fixing uses quarter turn fasteners, instead of screws, to secure the grille to a sub frame making removal and re-fitting after installation quick and easy.

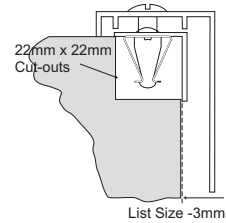

Concealed Bracket Fixing (Ref...CB)

Standard concealed bracket fixing can be used for units where aesthetics are of key importance and provide a secure and invisible means to fix/install units. Straps across the rear of the grille hold captive screws which locate into a loose secondary bracket. When offered into the opening the secondary bracket push clips over side rails fitted into the duct after which final tightening and alignment can be performed.

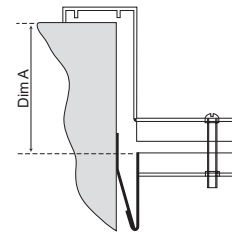

| Type | Grille Only Dim A | Grill c/w damper Dim A |
|--|----------------------|---------------------------|
| GH, GV, HH, HV, K, 2K, L3, L6, GECA, GECA1 | 50 | 100 |
| GHV, GVH | 73 | 123 |
| HHV, HVH | 78 | 128 |
| KG,F | 48 | 98 |

Concealed Leg Bracket Fixing (Ref...LB)

Special concealed bracket fixing is available where a secure yet invisible means to fix/install units is required in areas where our standard concealed fixing (CB) is unsuitable such as in plaster ceilings or non ducted installations.

Straps across the rear of the Grille hold captive screws which locate into a loose secondary bracket. Legs on the secondary bracket are manufactured to suit the structural thickness so that the unit can be tightened into position.

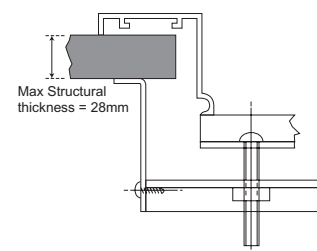



Volume Control

Opposed Blade Damper
(Ref.....DO)

Knob Operated Damper
(Ref.....DK)

Standard volume control is available with rear mounted opposed blade dampers operable by screwdriver through the grille face.

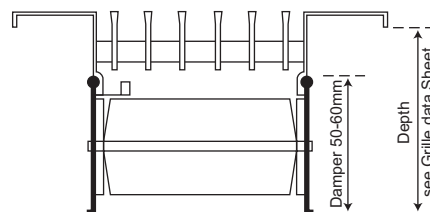

For easier volume control the standard opposed blade damper can be furnished with a permanent knob operation.

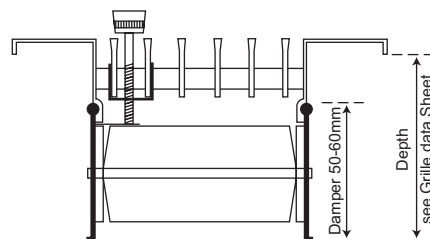

Plenum Boxes

A wide selection of Gilbert Grille types can be provided complete with a top or side entry plenum option. Robustly Fabricated from Galvanised or Zintec treated mild steel the plenums are supplied loose and come complete with all necessary fixing angles for drop rod support.

Both circular and square/rectangular spigot inlets are available and a number of volume control options can be fitted including quadrant, cord or teleflex operated flap damper and iris dampers.

Plenum internals are normally mill finish. Matt black internal or chlorinated rubber internal finish can be specified where required.

TOP CONNECTION
REF ...TCB

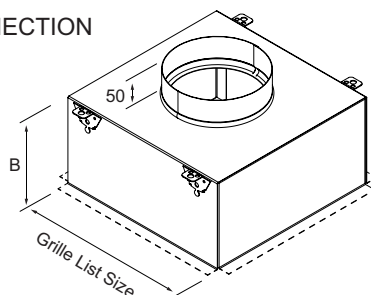

SIDE ENTRY
REF ...SEB

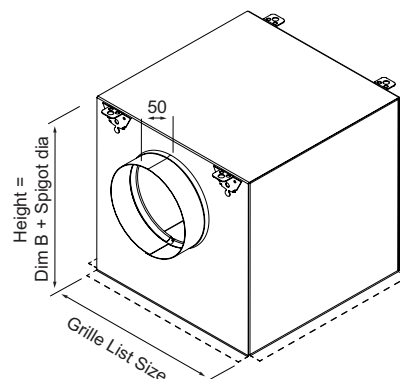

General Plenum Specification

- 0.7mm Galvanised mild steel plenum.
- Spigot Construction: Standard spigots (150, 200, and 250 dia) use plastic clip in spigots. Non standard and any with volume control use a sealed screw in steel spigot.

| TCB...TOP CONNECTION BOX | | Dim B (box depth) | | | | |
|--------------------------|-------------|--|-----|-----|--------|-----------|
| | | Std depth 150 increasing to 250mm as table below depending on which grille and plenum options are selected | | | | |
| | | DO - Opposed Blade Damper (grille) CBF - Concealed Bracket Fixing (grille) PM - Perforated Mesh (plenum) | | | | |
| TYPE OF GRILLE | EDGE TYPE | DO | CBF | PM | PM+CBF | DO+PM+CBF |
| GH,GV, | 20mm FLANGE | 150 | 150 | 150 | 150 | 250 |
| GHV,GVH | 20mm FLANGE | 150 | 150 | 150 | 250 | 250 |
| GN | KNIFE | 150 | 150 | 150 | 150 | 250 |
| GVHN,GHVN, | KNIFE | 150 | 150 | 150 | 250 | 250 |
| HH,HV, | 20mm FLANGE | 150 | 150 | 150 | 150 | 250 |
| HHV,HVH | 20mm FLANGE | 150 | 150 | 150 | 250 | 250 |
| GC | 20mm FLANGE | 150 | 150 | 150 | 150 | 250 |
| GECA | 20mm FLANGE | 150 | 150 | 150 | 150 | 250 |
| GEC | 20mm FLANGE | 150 | 150 | 150 | 150 | 250 |
| GECA-RC | KNIFE | 150 | 150 | 150 | 150 | 250 |
| K | 20mm FLANGE | 150 | 150 | 150 | 150 | 250 |
| KN, KG | KNIFE | 150 | 150 | 150 | 150 | 250 |
| PE | 20mm FLANGE | 150 | 150 | 150 | 150 | 250 |
| L, LG | 20mm FLANGE | 150 | 150 | 150 | 150 | 250 |
| LH | KNIFE | 150 | 150 | 150 | 150 | 250 |
| LN, LGN | KNIFE | 150 | 150 | 150 | 150 | 250 |

SEB....SIDE ENTRY BOX

For depth on SEB (side entry box) add the spigot diameter to the TCB depth

GRILLES

Options and Accessories

Plenum
Volume
Control

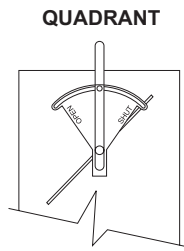

Ref. DQ

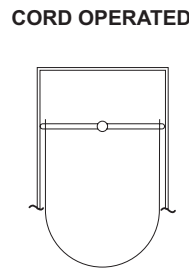

Ref. DC

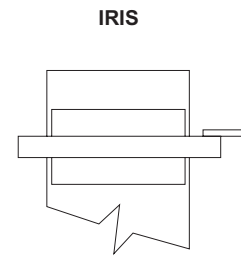

Ref. DI

Ordering
Specification
Plenum boxes
only.

(See Grille data sheets
for other ordering
specifications.)

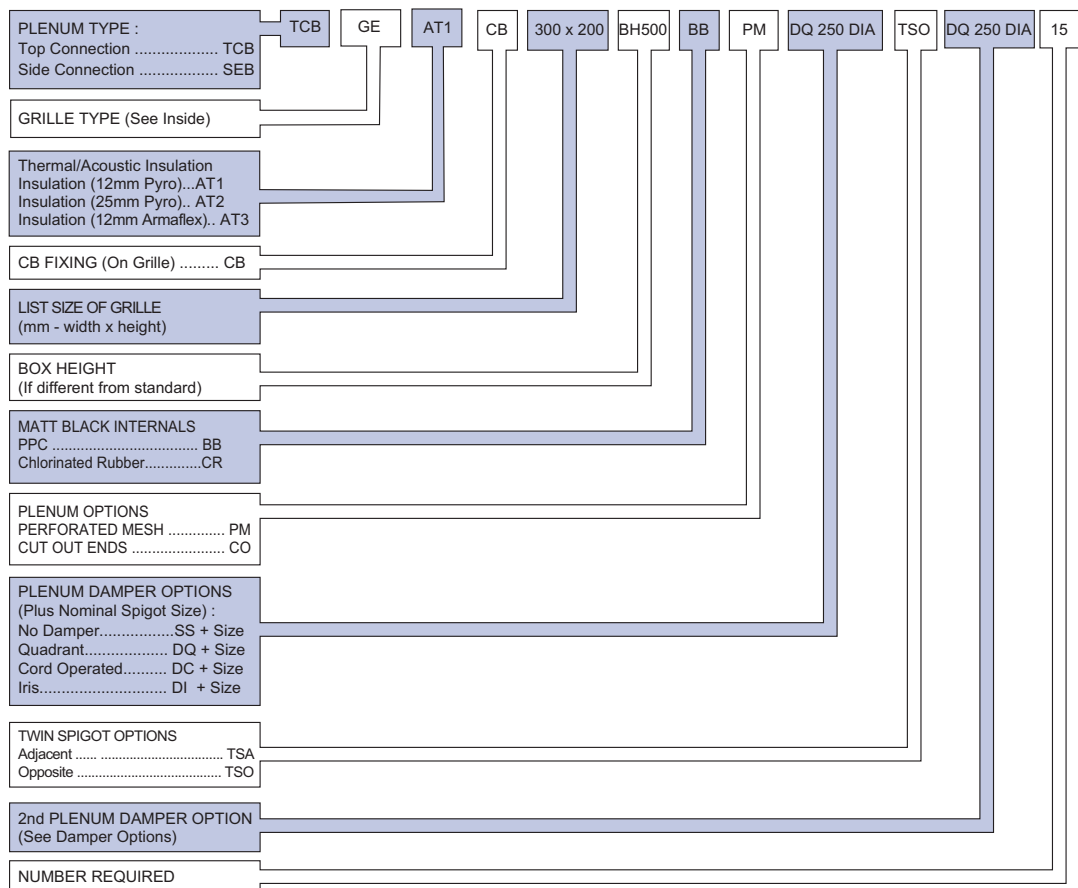

GILBERTS

Head Office and Works
GILBERTS (BLACKPOOL) LTD
 Gilair Works, Clifton Road,
 Blackpool.
 Lancashire FY4 4QT.
 Telephone: (01253) 766911
 Fax: (01253) 767941
 e-mail: sales@gilbertsblackpool.com
 Web: www.gilbertsblackpool.com

