

SERIES DG

Louvred Face
Ceiling Diffusers

PUBLICATION

DIFFUSERS 1

APRIL 2012

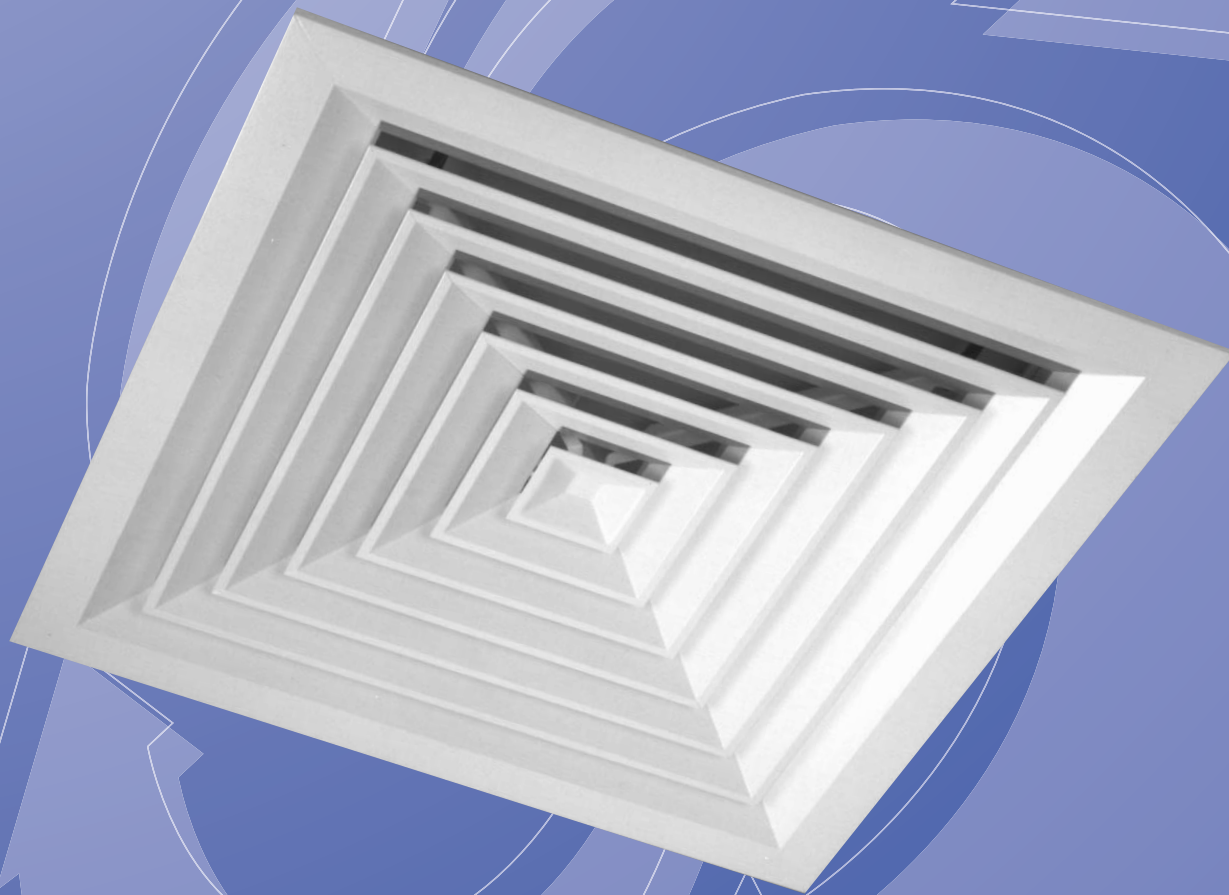

Features

- Attractive Louvred Face Design.
- 4 Frame/Border Styles.
- 9 Different Air Pattern Core Options.
- Spring Loaded Removable Core.
- Complementary Top & Side Entry Connection Boxes.
- Pressed and Extruded aluminium Construction.



GILBERTS

SERIES DG

Louvred Face Ceiling Diffusers

Introduction

Gilberts DG Series of Louvred Face Diffusers offer a distinct new evolution on a popular design theme. Combining up-to-date styling and design technology to blend with modern architecture the DG Series provide an unrivalled blend of performance and aesthetics featuring a restyled improved blade profile to give a balanced visual appearance from all aspects and angles and to ensure a clean horizontal air distribution pattern.

Units are available in 1, 2, 3 or 4 way blow, in both square and rectangular forms and in a wide variety of sizes ranging from 150 x 150 neck size up to 600 x 600 in 75mm

increments. (Where uniform core appearance is needed clip on blanking plates are available to convert air patterns).

All Gilberts DG Units benefit from a robust spring loaded removable core assembly which allows easy access to dampers for initial balancing or cleaning and safety cords to firmly secure the core to the diffuser frame. In keeping with contemporary ceiling design the series is available with 4 specific frame border styles integrating operational flexibility by matching different popular ceiling types.

Standard Series Options:

- Type DGA** : Standard border suitable for both suspended and plaster ceiling applications.
- Type DGB** : Special border adapted for clip in ceiling grid applications.
- Type DGC** : Special border adapted for tegular and drop in tile ceiling grids.
- Type DGD** : Narrow border option providing a higher capacity neck size suitable for suspended ceiling applications.

Further adaptations on these border frame platforms provides other distinct permutations allowing integration of the DG into almost any ceiling type, specification or design. For volume control the standard screwdriver operated opposed blade damper is available attached directly to the diffuser. Alternative plenum volume control options of a rotary damper, for top connection and quadrant or cord operated flap type damper for top/side connection can also be specified. Standard finish for all DG Series is a Polyester Powder White. Other colours and finishes are available on request.

Selection Procedure

Having established the position where terminals can be sited, refer to data showing core pattern details and select the suitable direction pattern required. Knowing the volume and throw for each diffuser in question then check :

- a) Recommended limit of volume per direction according to ceiling height (table 1) with throw of air required lying between the max and min values.
- b) Note sound level from performance data and check this recommendations shown on table .
- c) Determine the total pressure drop from performance data.

Table 1

Ceiling Height	Max vol per direction (each diffuser)	Cooling Differential Maximum
2.5m	0.090 m ³ /s	12°C
3.0m	0.200 m ³ /s	12°C
3.5m	0.350 m ³ /s	12°C

Area to be served	Recommended Maximum NC Levels
Sound Broadcasting, Recording Studios, TV (Audience Studios)	15 - 20 20 - 25
Lecture Theatres, Cinemas, Concert Halls, Boardroom/Ex Offices Lounge, Conference Room, Court Room, Churches, Private Bedrooms	25 - 30
Operating Theatres, Hospital Wards, Staff Room, Class Rooms, Ballroom, Banquet Room, Library, Bank, Museum, Offices	30 - 40
Restaurants, Department Stores, Computer Suite, Washroom Toilet	35 - 40
Laundries, Kitchens, Swimming Pools, Sports Arena	40 - 45
Garage, Light Engineering Workshop	45 - 50
Heavy Engineering Workshop	50 - 65

Performance Data

The performance data tables provide information for cooling, ventilation and heating applications. They are intended to be aids to heating and air conditioning engineers.

References used :

Pressure : All pressures are in Pa (N/m²) TP = Total Pressure SP = Negative Static Pressure

Throw : The first figure is the throw that corresponds to 0.5 m/s, and the second figure corresponds to 0.25 m/s.

Sound : NC values are based on a room absorption of 8db, re 10⁻¹² watts and for one diffuser, with OBD Damper fully open.

Return Factors : If the unit is used as a return inlet, the performance data is obtained by applying the factors in the following manner : a) Sound : Add factor to the NC value listed

b) Negative static pressure : Multiply the factor by the total pressure listed in the tables.

Return Example : 150 x 150 DGA4 with 0.062 m³/s being returned through the unit

Return NC = 18 + 1 = 19

Return Pressure = (-SP) 20 x 1.1 = 22 Pa

Plenum Boxes : Where plenum boxes are attached to diffusers there will be an effect on both the noise and pressure drop values. Top connection boxes have little effect unless spigot connection velocities exceed 4 m/s. However for Side entry boxes an increase should be applied to the tables of 25% for supply pressure drops and 40% for extract. The following spigot velocity figures indicate expected NC levels in the conditioned space and are based on a room absorption figure of 8db, re 10⁻¹² watts.

Spigot Velocity 3.0 m/s NC Level 30-35

Spigot Velocity 2.3 m/s NC Level 25-30

Spigot Velocity 2.5 m/s NC Level 30

Spigot Velocity 2.0 m/s NC Level 25

The performance data for all Gilberts products is derived using a Gilberts plenum design and specification. Performance cannot be guaranteed where alternative plenum designs are used.

Gilberts Supply Diffusers have been tested within the range of +/- 10°C (as recommended in the HEVAC Guide to Air Distribution Technology). For any other temperature differential requirements please contact our Technical Department.



Facilities

REMOVABLE CORE (fig.1)

The Louvred Face Core on all DG Series units is spring loaded to allow easy removal from the frame for cleaning, damper balancing and adjustment. To remove the core simply identify its spring loaded side and gently push the core horizontally towards the outer frame. Upon reaching its maximum movement the clips or pins on the opposite side of the core will have disengaged from the frame allowing that side to lower for full removal.

Note : Although safety cords are fitted the core will remove sufficiently to clear the frame and lower but will remain safely secured to prevent it from falling.

The removable core facility also allows different core styles to interchange on site where necessary.

(fig.1)

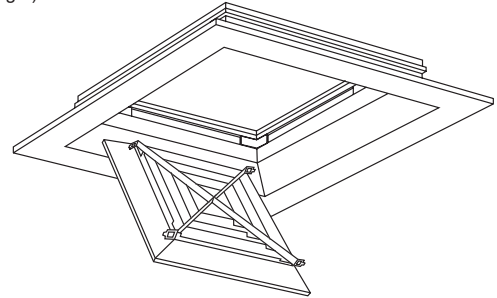

DAMPER CONTROL (fig.2)

The DG Series now offers a variety of alternative damper control choices. Standard Opposed Blade Dampers remain an option for all units with screwdriver operation. In addition, however, a Rotary Damper is also available for units with Top Connection Box (TCB) type plenum. The rotary damper benefits from a low depth profile and comprises of a hit and miss style circular sliding plate which can be adjusted using finger tabs from the damper face.

For top and side entry plenums quadrant and cord operated single blade flap type dampers can also be utilised or, for a more sophisticated form of volume control, Iris type dampers.

(fig.2)

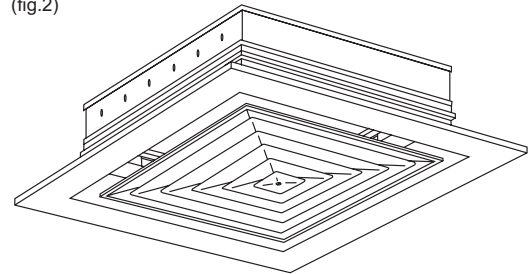

SAFETY CORD (fig.3)

A standard feature on DG Series are the Nylon Safety Cords.

The cords which are approximately 150mm in length bind the removable core to the diffuser frame. A useful safety feature, the cords will allow core removal but will prevent the core from accidentally falling to the ground.

(fig.3)

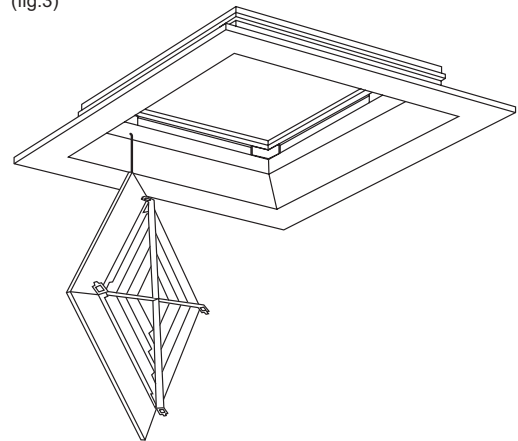

NON VISION COWL (fig.4)

For non-ducted installations DG Units can be fitted with a matt black non-visual cowl plate (Ref: NVC/DG) at the rear to prevent see through vision into the ceiling void.

(fig.4)

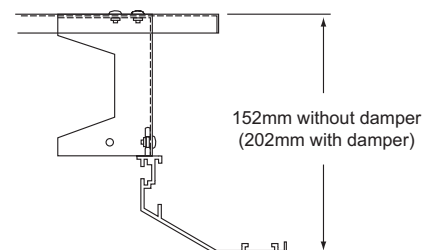

SERIES DG

Louvred Face Ceiling Diffusers

Coanda Plate

Available to suit all square sizes the coanda plate fixes to the back of the face flange of the diffuser to create a ceiling effect where diffusers are mounted in free space such as on exposed ductwork. The coanda effect can be used to increase the throw of the diffuser in these applications by allowing the air to flow across the plate and travel further before dropping into the occupied zone.

Standard Coanda width = List Size + 374mm

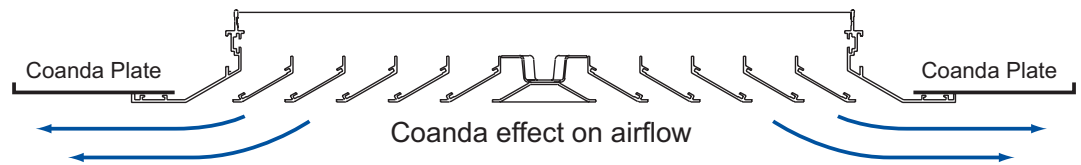

Neck Reducing Plate

Neck reduction plates can be fitted to the rear of all square face diffusers and are designed to limit airflow through the diffuser to a smaller neck size. Typically they are used on standard 600 sq ceiling grid size diffusers allowing the tile replacement size to be used throughout an installation whilst matching capacity to the required volume.

If opposed blade dampers are used in conjunction with a neck reduction plate the damper is also downsized with the neck to save on cost.

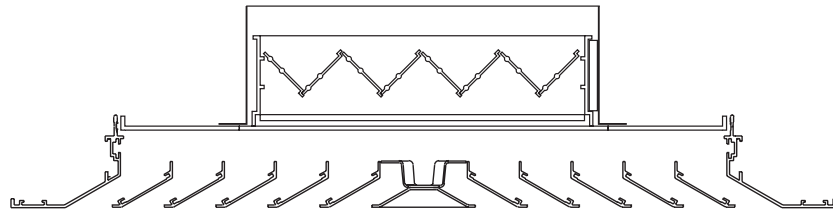

Air Pattern Options

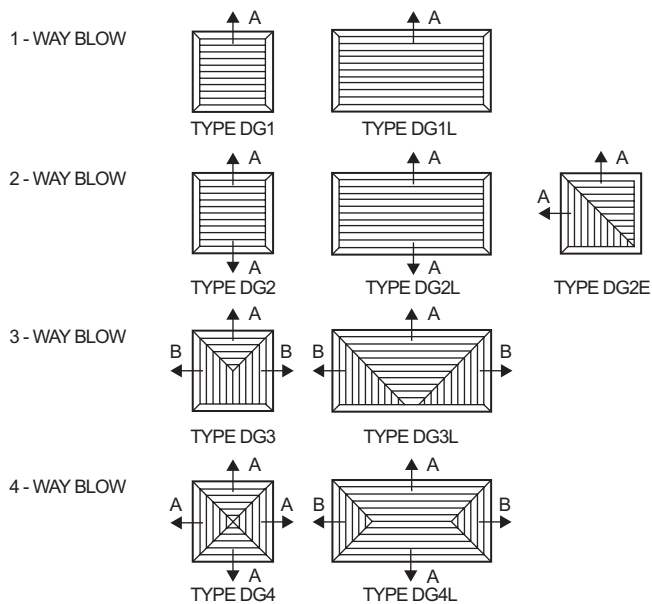



Series DG

TYPE DGA Standard Border

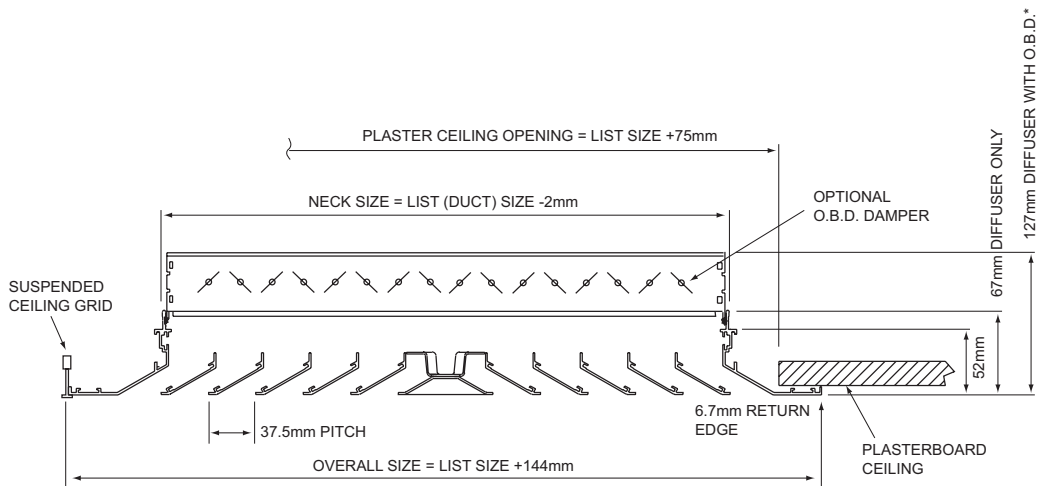

LIST SIZE RANGE: 150 x 150 UPTO 600 x 600 IN 75mm INCREMENTS

TYPE DGB Clip in Border

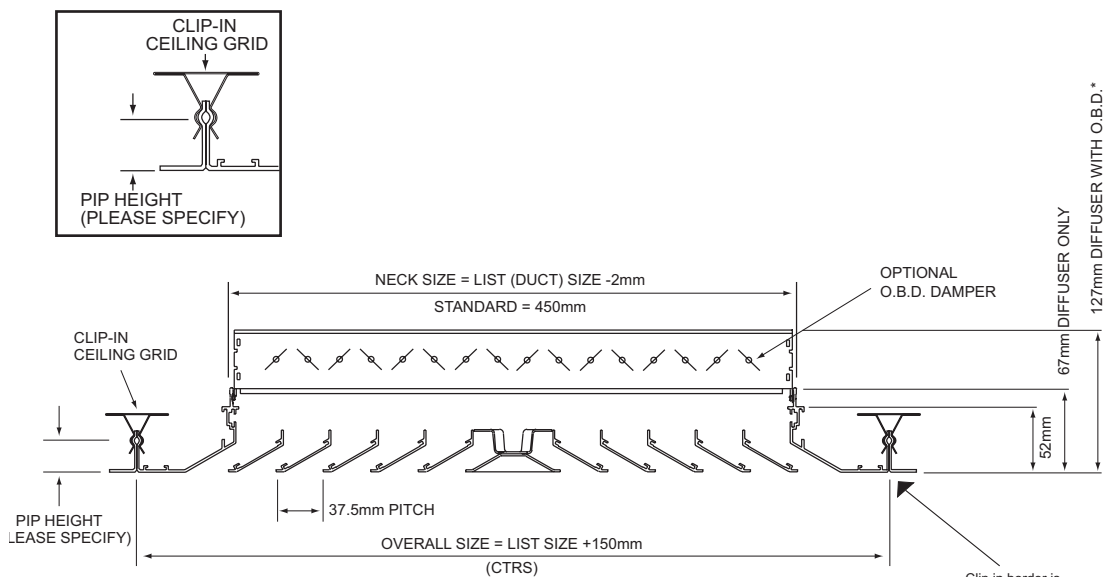

LIST SIZE RANGE: 450 x 450 ONLY (600 O/A)

* Max depth - Depth may be lower depending on damper fitment. Please check where necessary

SERIES DG

Louvred Face Ceiling Diffusers

Series DG TYPE DGC Tegular Border

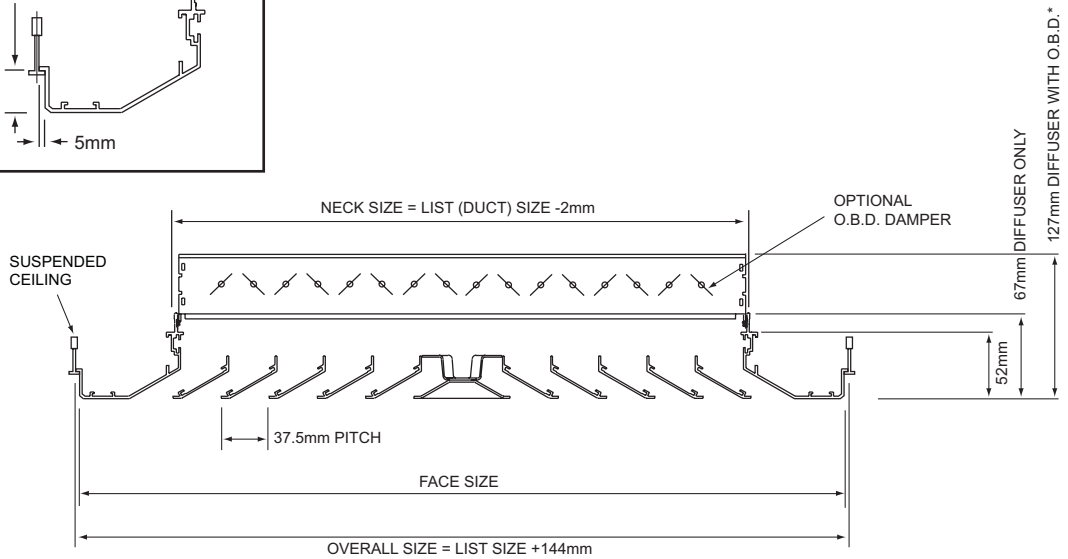
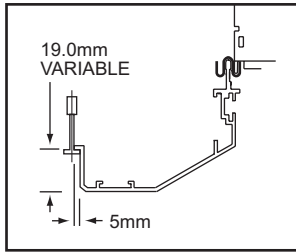

Overall Size Dims

- List Size 450sq = 594sq O/A (584sq Face Size)
- List Size 440sq = 584sq O/A (574sq Face Size)
- List Size 350sq = 494sq O/A (484sq Face Size)
- List Size 340sq = 484sq O/A (474sq Face Size)

TYPE DGD Narrow Border

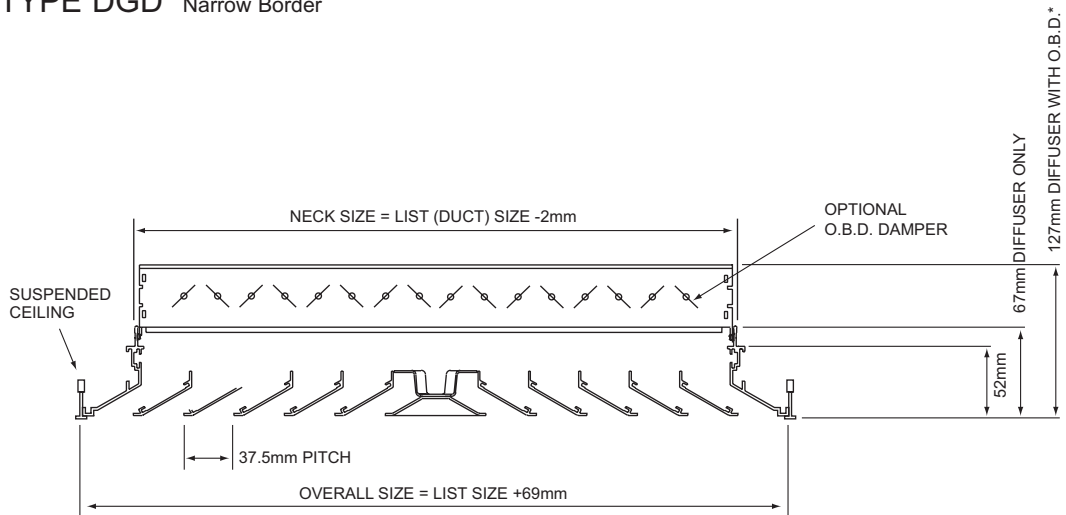

LIST SIZE RANGE: 150 x 150 UPTO 600 x 600 IN 75mm INCREMENTS
STANDARD SIZE: 525 x 525 (594 o/a)

* Max depth - Depth may be lower depending on damper fitment. Please check where necessary



Plenum & Connection Boxes

TYPE TCB: TOP CONNECTION BOX

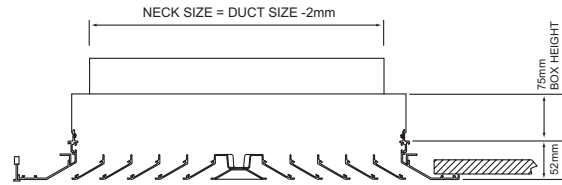
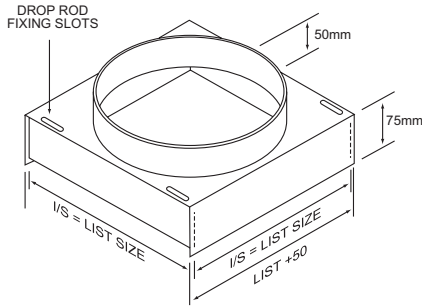

TYPE SEB: SIDE ENTRY BOX

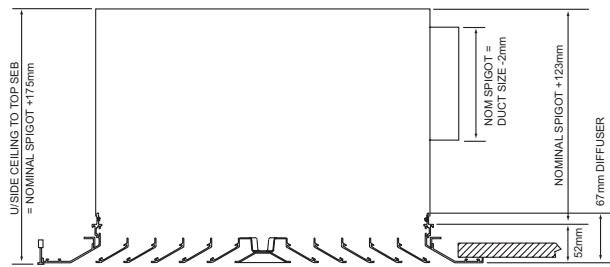
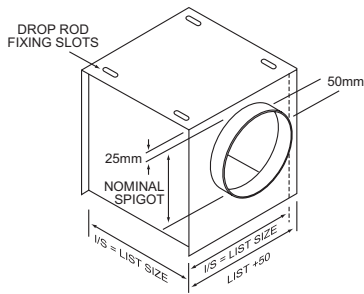

General Plenum Specification

- 0.7mm Galvanised or Zintec coated mild steel plenum.
- Spigot Construction: Standard size spigots use plastic clip-in spigots. Non standard a sealed screw in spigot.
- Twin spigot options are also available. Twin spigots can be fitted on opposed sides of the box (ref ... TSO) or adjacent sides at 90° to each other ref ... TSA).

Plenum Volume Control

PLENUM TYPE TCB & SEB
ROTARY DAMPER - REF: DR

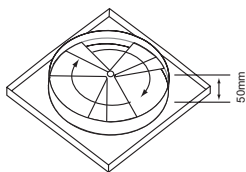

QUADRANT DAMPER - REF:DQ

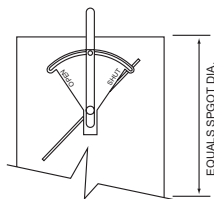

CORD OP DAMPER - REF:DC

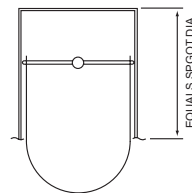

IRIS DAMPER - REF DI

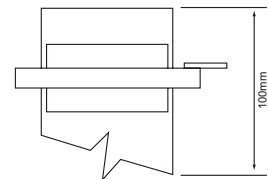

SIZE OPTIONS
150, 160, 200, 225
250, 300, 350, 400
& 450 Dia

SERIES DG

Louvered Face Ceiling Diffusers

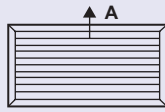

ONE- WAY BLOW Type DG1L

NECK SIZE AREA m ² RETURN – SP RETURN N.C.	NECK VEL m/s TOTAL PRESSURE Pa	1.5 6	1.75 8	2.0 11	2.25 14	2.5 17	2.75 20	3.0 24
225 x 150 0.0337 (1.2) x T.P. SUPPLY N.C. + 0	TOTAL m ³ /s m ³ /s PER SIDE N.C. LEVEL THROW m	A .052 B .052 –	A .06 B .06 –	A .068 B .068 –	A .076 B .076 –	A .084 B .084 –	A .092 B .092 –	A .10 B .10 –
300 x 150 0.045 (1.6) x T.P. SUPPLY N.C. + 1	TOTAL m ³ /s m ³ /s PER SIDE N.C. LEVEL THROW m	A .068 B .068 –	A .078 B .078 –	A .09 B .09 –	A .102 B .102 –	A .112 B .112 –	A .124 B .124 –	A .136 B .136 –
375 x 150 0.0562 (1.9) x T.P. SUPPLY N.C. + 1	TOTAL m ³ /s m ³ /s PER SIDE N.C. LEVEL THROW m	A .084 B .084 –	A .098 B .098 –	A .112 B .112 –	A .126 B .126 –	A .14 B .14 –	A .154 B .154 –	A .168 B .168 –
450 x 150 0.0675 (2.6) x T.P. SUPPLY N.C. + 2	TOTAL m ³ /s m ³ /s PER SIDE N.C. LEVEL THROW m	A .101 B .101 –	A .118 B .118 –	A .135 B .135 –	A .151 B .151 –	A .168 B .168 –	A .185 B .185 –	A .202 B .202 –
525 x 150 0.0787 (3.0) x T.P. SUPPLY N.C. + 3	TOTAL m ³ /s m ³ /s PER SIDE N.C. LEVEL THROW m	A .118 B .118 –	A .137 B .137 –	A .157 B .157 –	A .177 B .177 –	A .196 B .196 –	A .216 B .216 –	A .236 B .236 –
600 x 150 0.09 (4.0) x T.P. SUPPLY N.C. + 4	TOTAL m ³ /s m ³ /s PER SIDE N.C. LEVEL THROW m	A .135 B .135 –	A .157 B .157 –	A .18 B .18 –	A .202 B .202 –	A .225 B .225 –	A .247 B .247 –	A .27 B .27 –
300 x 225 0.0675 (1.4) x T.P. SUPPLY N.C. + 2	TOTAL m ³ /s m ³ /s PER SIDE N.C. LEVEL THROW m	A .10 B .10 –	A .118 B .118 –	A .135 B .135 –	A .151 B .151 –	A .168 B .168 –	A .185 B .185 –	A .202 B .202 –
375 x 225 0.0843 (1.6) x T.P. SUPPLY N.C. + 3	TOTAL m ³ /s m ³ /s PER SIDE N.C. LEVEL THROW m	A .126 B .126 –	A .147 B .147 –	A .168 B .168 –	A .189 B .189 –	A .21 B .21 –	A .231 B .231 –	A .252 B .252 –
450 x 225 0.101 (2.0) x T.P. SUPPLY N.C. + 3	TOTAL m ³ /s m ³ /s PER SIDE N.C. LEVEL THROW m	A .151 B .151 –	A .176 B .176 –	A .202 B .202 –	A .227 B .227 –	A .252 B .252 –	A .277 B .277 –	A .303 B .303 –
525 x 225 0.118 (2.2) x T.P. SUPPLY N.C. + 4	TOTAL m ³ /s m ³ /s PER SIDE N.C. LEVEL THROW m	A .177 B .177 –	A .206 B .206 –	A .236 B .236 –	A .265 B .265 –	A .295 B .295 –	A .324 B .324 –	A .354 B .354 –
600 x 225 0.135 (2.7) x T.P. SUPPLY N.C. + 4	TOTAL m ³ /s m ³ /s PER SIDE N.C. LEVEL THROW m	A .202 B .202 –	A .236 B .236 –	A .27 B .27 –	A .303 B .303 –	A .337 B .337 –	A .371 B .371 –	A .405 B .405 –
375 x 300 0.112 (1.6) x T.P. SUPPLY N.C. + 2	TOTAL m ³ /s m ³ /s PER SIDE N.C. LEVEL THROW m	A .168 B .168 –	A .196 B .196 –	A .224 B .224 –	A .252 B .252 –	A .28 B .28 –	A .308 B .308 –	A .336 B .336 –
450 x 300 0.135 (1.8) x T.P. SUPPLY N.C. + 3	TOTAL m ³ /s m ³ /s PER SIDE N.C. LEVEL THROW m	A .202 B .202 –	A .236 B .236 –	A .27 B .27 –	A .303 B .303 –	A .337 B .337 –	A .371 B .371 –	A .405 B .405 –
525 x 300 0.157 (2.0) x T.P. SUPPLY N.C. + 5	TOTAL m ³ /s m ³ /s PER SIDE N.C. LEVEL THROW m	A .235 B .235 –	A .274 B .274 –	A .314 B .314 –	A .353 B .353 –	A .392 B .392 –	A .431 B .431 –	A .471 B .471 –
600 x 300 0.18 (2.5) x T.P. SUPPLY N.C. + 5	TOTAL m ³ /s m ³ /s PER SIDE N.C. LEVEL THROW m	A .27 B .27 –	A .315 B .315 –	A .36 B .36 –	A .405 B .405 –	A .45 B .45 –	A .495 B .495 –	A .54 B .54 –
450 x 375 0.168 (2.0) x T.P. SUPPLY N.C. + 4	TOTAL m ³ /s m ³ /s PER SIDE N.C. LEVEL THROW m	A .252 B .252 –	A .294 B .294 –	A .336 B .336 –	A .378 B .378 –	A .42 B .42 –	A .462 B .462 –	A .504 B .504 –
525 x 375 0.196 (2.1) x T.P. SUPPLY N.C. + 5	TOTAL m ³ /s m ³ /s PER SIDE N.C. LEVEL THROW m	A .294 B .294 –	A .343 B .343 –	A .392 B .392 –	A .441 B .441 –	A .49 B .49 –	A .539 B .539 –	A .588 B .588 –
600 x 375 0.225 (2.5) x T.P. SUPPLY N.C. + 6	TOTAL m ³ /s m ³ /s PER SIDE N.C. LEVEL THROW m	A .337 B .337 –	A .393 B .393 –	A .45 B .45 –	A .506 B .506 –	A .562 B .562 –	A .618 B .618 –	A .675 B .675 –
525 x 450 0.236 (2.2) x T.P. SUPPLY N.C. + 5	TOTAL m ³ /s m ³ /s PER SIDE N.C. LEVEL THROW m	A .354 B .354 –	A .413 B .413 –	A .472 B .472 –	A .531 B .531 –	A .59 B .59 –	A .649 B .649 –	A .708 B .708 –
600 x 450 0.27 (2.4) x T.P. SUPPLY N.C. + 6	TOTAL m ³ /s m ³ /s PER SIDE N.C. LEVEL THROW m	A .405 B .405 –	A .472 B .472 –	A .54 B .54 –	A .607 B .607 –	A .675 B .675 –	A .742 B .742 –	A .81 B .81 –
600 x 525 0.315 (3.0) x T.P. SUPPLY N.C. + 7	TOTAL m ³ /s m ³ /s PER SIDE N.C. LEVEL THROW m	A .472 B .472 –	A .551 B .551 –	A .63 B .63 –	A .708 B .708 –	A .787 B .787 –	A .866 B .866 –	A .945 B .945 –

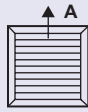

ONE- WAY BLOW Type DG1

NECK SIZE AREA m ² RETURN – SP RETURN N.C.	NECK VEL m/s TOTAL PRESSURE Pa	1.5 6	1.75 8	2.0 11	2.25 14	2.5 17	2.75 20	3.0 24
150 x 150 0.0225 (1.1) x T.P. SUPPLY N.C. + 1	TOTAL m ³ /s m ³ /s PER SIDE N.C. LEVEL THROW m	A .034 B .034 – 2/4	A .04 B .04 – 2.2/4.2	A .045 B .045 – 2.5/4.5	A .051 B .051 – 2.7/4.8	A .056 B .056 15 – 3/5	A .062 B .062 18 – 3.1/5.5	A .067 B .067 20 – 3.3/6
225 x 225 0.05 (1.2) x T.P. SUPPLY N.C. + 2	TOTAL m ³ /s m ³ /s PER SIDE N.C. LEVEL THROW m	A .075 B .075 – 3/5	A .087 B .087 – 3.5/5.5	A .1 B .1 – 4/6	A .112 B .112 15 – 4.2/6.5	A .125 B .125 18 – 4.5/7	A .135 B .135 22 – 4.6/7.5	A .15 B .15 24 – 4.7/8
300 x 300 0.09 (1.3) x T.P. SUPPLY N.C. + 4	TOTAL m ³ /s m ³ /s PER SIDE N.C. LEVEL THROW m	A .135 B .135 – 4/6.5	A .157 B .157 – 4.2/6.7	A .18 B .18 15 – 4.5/7	A .202 B .202 18 – 4.7/8	A .225 B .225 21 – 5/8.5	A .247 B .247 24 – 5.2/8.7	A .27 B .27 27 – 5.4/9
375 x 375 0.14 (1.8) x T.P. SUPPLY N.C. + 5	TOTAL m ³ /s m ³ /s PER SIDE N.C. LEVEL THROW m	A .21 B .21 – 4.5/7	A .245 B .245 – 4.7/8	A .28 B .28 16 – 5/9	A .315 B .315 20 – 5.2/9.5	A .35 B .35 23 – 5.5/10	A .385 B .385 25 – 5.7/10.5	A .42 B .42 29 – 6/11
450 x 450 0.2025 (2.1) x T.P. SUPPLY N.C. + 6	TOTAL m ³ /s m ³ /s PER SIDE N.C. LEVEL THROW m	A .303 B .303 – 4.8/8	A .354 B .354 15 – 5.1/8.5	A .405 B .405 18 – 5.5/9	A .455 B .455 21 – 6/10	A .506 B .506 25 – 6.5/11	A .566 B .566 27 – 6.7/11.5	A .607 B .607 31 – 7/11.5
525 x 525 0.2756 (2.6) x T.P. SUPPLY N.C. + 8	TOTAL m ³ /s m ³ /s PER SIDE N.C. LEVEL THROW m	A .413 B .413 – 5/9	A .482 B .482 16 – 5.5/9.7	A .55 B .55 20 – 6/10.5	A .62 B .62 23 – 6.5/11.2	A .689 B .689 27 – 7/12	A .758 B .758 30 – 7.2/12.5	A .826 B .826 33 – 7.5/13
600 x 600 0.36 (2.7) x T.P. SUPPLY N.C. + 9	TOTAL m ³ /s m ³ /s PER SIDE N.C. LEVEL THROW m	A .54 B .54 15 – 6/10	A .63 B .63 18 – 6.5/11	A .72 B .72 21 – 7/12	A .81 B .81 25 – 7.3/12.8	A .9 B .9 28 – 7.5/13.5	A .99 B .99 30 – 7.8/13.8	A 1.08 B 1.08 34 – 8/14

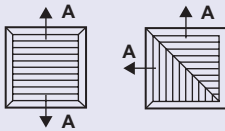

TWO- WAY BLOW Types DG2 and DG2E

NECK SIZE AREA m ² RETURN – SP RETURN N.C.	NECK VEL m/s TOTAL PRESSURE Pa	1.5 6	1.75 8	2.0 11	2.25 14	2.5 17	2.75 20	3.0 24
150 x 150 0.0225 (1.1) x T.P. SUPPLY N.C. + 1	TOTAL m ³ /s m ³ /s PER SIDE N.C. LEVEL THROW m	A .034 B .017 – 2/3	A .04 B .02 – 2.1/3.3	A .045 B .022 – 2.3/3.6	A .051 B .025 – 2.4/4	A .056 B .028 15 – 2.5/4.2	A .062 B .031 18 – 2.7/4.4	A .067 B .033 20 – 3/4.6
225 x 225 0.05 (1.2) x T.P. SUPPLY N.C. + 2	TOTAL m ³ /s m ³ /s PER SIDE N.C. LEVEL THROW m	A .075 B .037 – 2.4/4	A .087 B .043 – 2.7/4.6	A .1 B .05 – 3/5	A .112 B .056 15 – 3/5.3	A .125 B .062 18 – 3.2/5.6	A .135 B .067 22 – 3.3/5.8	A .15 B .075 24 – 3.5/6
300 x 300 0.09 (1.3) x T.P. SUPPLY N.C. + 4	TOTAL m ³ /s m ³ /s PER SIDE N.C. LEVEL THROW m	A .135 B .067 – 2.9/5.0	A .157 B .078 – 3.2/5.4	A .18 B .09 15 – 3.5/6.9	A .202 B .101 18 – 3.7/6.2	A .225 B .112 21 – 4/6.5	A .247 B .123 24 – 4.2/7	A .27 B .135 27 – 4.4/7.2
375 x 375 0.14 (1.8) x T.P. SUPPLY N.C. + 5	TOTAL m ³ /s m ³ /s PER SIDE N.C. LEVEL THROW m	A .21 B .105 – 3.5/6.0	A .245 B .122 – 3.7/6.5	A .28 B .14 16 – 4/7	A .315 B .157 20 – 4.2/7.4	A .35 B .175 23 – 4.5/7.9	A .385 B .192 25 – 4.7/8.4	A .42 B .21 29 – 5/9
450 x 450 0.2025 (2.1) x T.P. SUPPLY N.C. + 6	TOTAL m ³ /s m ³ /s PER SIDE N.C. LEVEL THROW m	A .303 B .151 – 3.7/6.5	A .354 B .177 15 – 4/6.9	A .405 B .202 18 – 4.2/7.2	A .455 B .227 21 – 4.6/8	A .506 B .253 25 – 5/8.8	A .556 B .278 27 – 5/9.1	A .607 B .303 31 – 5.2/9.4
525 x 525 0.2756 (2.6) x T.P. SUPPLY N.C. + 8	TOTAL m ³ /s m ³ /s PER SIDE N.C. LEVEL THROW m	A .413 B .206 – 4/7.2	A .482 B .241 16 – 4.5/8	A .55 B .275 20 – 5/8.8	A .62 B .31 23 – 5.2/9.4	A .689 B .344 27 – 5.5/10	A .758 B .379 30 – 5.7/10.5	A .826 B .413 33 – 6/11
600 x 600 0.36 (2.7) x T.P. SUPPLY N.C. + 9	TOTAL m ³ /s m ³ /s PER SIDE N.C. LEVEL THROW m	A .54 B .27 15 – 4.5/8	A .63 B .315 18 – 4.8/8.6	A .72 B .36 21 – 5.2/9.2	A .81 B .405 25 – 5.7/10	A .9 B .45 28 – 6.2/10.8	A .99 B .495 30 – 6.5/11.1	A 1.08 B 0.54 34 – 6.7/11.4

SERIES DG

Louvered Face Ceiling Diffusers

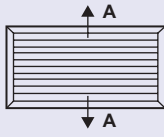

TWO- WAY BLOW Type DG2L

NECK SIZE AREA m ² RETURN - SP RETURN N.C.	NECK VEL m/s TOTAL PRESSURE Pa	1.5 6	1.75 8	2.0 11	2.25 14	2.5 17	2.75 20	3.0 24
225 x 150 0.0337 (1.2) x T.P. SUPPLY N.C. + 0	TOTAL m ³ /s m ³ /s PER SIDE N.C. LEVEL THROW m	A .052 B .026 -	A .06 B .03 -	A .068 B .034 10	A .076 B .038 14	A .084 B .042 17	A .092 B .046 20	A .10 B .05 23
300 x 150 0.045 (1.6) x T.P. SUPPLY N.C. + 1	TOTAL m ³ /s m ³ /s PER SIDE N.C. LEVEL THROW m	A .068 B .034 -	A .078 B .039 -	A .09 B .045 11	A .102 B .051 15	A .112 B .056 18	A .124 B .062 21	A .136 B .068 24
375 x 150 0.0562 (1.9) x T.P. SUPPLY N.C. + 1	TOTAL m ³ /s m ³ /s PER SIDE N.C. LEVEL THROW m	A .084 B .042 -	A .098 B .049 -	A .112 B .056 12	A .126 B .063 15	A .14 B .07 19	A .154 B .077 23	A .168 B .084 25
450 x 150 0.0675 (2.6) x T.P. SUPPLY N.C. + 2	TOTAL m ³ /s m ³ /s PER SIDE N.C. LEVEL THROW m	A .101 B .050 -	A .118 B .059 -	A .135 B .067 13	A .151 B .075 16	A .168 B .084 20	A .185 B .092 24	A .202 B .101 26
525 x 150 0.0787 (3.0) x T.P. SUPPLY N.C. + 3	TOTAL m ³ /s m ³ /s PER SIDE N.C. LEVEL THROW m	A .118 B .059 -	A .137 B .068 -	A .157 B .078 13	A .177 B .088 16	A .196 B .098 20	A .216 B .108 24	A .236 B .118 26
600 x 150 0.09 (4.0) x T.P. SUPPLY N.C. + 4	TOTAL m ³ /s m ³ /s PER SIDE N.C. LEVEL THROW m	A .135 B .067 -	A .157 B .078 -	A .18 B .09 14	A .202 B .101 17	A .225 B .112 21	A .247 B .123 25	A .27 B .135 27
300 x 225 0.0675 (1.4) x T.P. SUPPLY N.C. + 2	TOTAL m ³ /s m ³ /s PER SIDE N.C. LEVEL THROW m	A .10 B .05 -	A .118 B .059 -	A .135 B .067 13	A .151 B .075 16	A .168 B .084 20	A .185 B .092 24	A .202 B .101 26
375 x 225 0.0843 (1.6) x T.P. SUPPLY N.C. + 3	TOTAL m ³ /s m ³ /s PER SIDE N.C. LEVEL THROW m	A .126 B .063 -	A .147 B .073 -	A .168 B .084 14	A .189 B .094 17	A .21 B .11 21	A .231 B .115 25	A .252 B .126 27
450 x 225 0.101 (2.0) x T.P. SUPPLY N.C. + 3	TOTAL m ³ /s m ³ /s PER SIDE N.C. LEVEL THROW m	A .151 B .075 -	A .176 B .088 -	A .202 B .101 15	A .227 B .113 18	A .252 B .126 22	A .277 B .139 26	A .303 B .151 28
525 x 225 0.118 (2.2) x T.P. SUPPLY N.C. + 4	TOTAL m ³ /s m ³ /s PER SIDE N.C. LEVEL THROW m	A .177 B .088 -	A .206 B .103 -	A .236 B .118 15	A .265 B .132 18	A .295 B .147 22	A .324 B .162 26	A .354 B .177 28
600 x 225 0.135 (2.7) x T.P. SUPPLY N.C. + 4	TOTAL m ³ /s m ³ /s PER SIDE N.C. LEVEL THROW m	A .202 B .101 -	A .236 B .118 -	A .27 B .135 16	A .303 B .151 19	A .337 B .168 23	A .371 B .185 27	A .405 B .202 29
375 x 300 0.112 (1.6) x T.P. SUPPLY N.C. + 2	TOTAL m ³ /s m ³ /s PER SIDE N.C. LEVEL THROW m	A .168 B .084 -	A .196 B .098 -	A .224 B .112 16	A .252 B .126 19	A .28 B .14 23	A .308 B .154 27	A .336 B .168 29
450 x 300 0.135 (1.8) x T.P. SUPPLY N.C. + 3	TOTAL m ³ /s m ³ /s PER SIDE N.C. LEVEL THROW m	A .202 B .101 -	A .236 B .118 -	A .27 B .135 17	A .303 B .151 20	A .337 B .168 24	A .371 B .185 28	A .405 B .202 30
525 x 300 0.157 (2.0) x T.P. SUPPLY N.C. + 5	TOTAL m ³ /s m ³ /s PER SIDE N.C. LEVEL THROW m	A .235 B .118 -	A .274 B .137 -	A .314 B .157 17	A .353 B .177 20	A .392 B .196 24	A .431 B .216 28	A .471 B .236 30
600 x 300 0.18 (2.5) x T.P. SUPPLY N.C. + 5	TOTAL m ³ /s m ³ /s PER SIDE N.C. LEVEL THROW m	A .27 B .135 -	A .315 B .157 -	A .36 B .18 18	A .405 B .202 21	A .45 B .225 25	A .495 B .247 29	A .54 B .27 31
450 x 375 0.188 (2.0) x T.P. SUPPLY N.C. + 4	TOTAL m ³ /s m ³ /s PER SIDE N.C. LEVEL THROW m	A .252 B .126 -	A .294 B .147 -	A .336 B .168 18	A .378 B .189 21	A .42 B .21 25	A .462 B .231 29	A .504 B .252 31
525 x 375 0.196 (2.1) x T.P. SUPPLY N.C. + 5	TOTAL m ³ /s m ³ /s PER SIDE N.C. LEVEL THROW m	A .294 B .147 -	A .343 B .171 -	A .392 B .196 18	A .441 B .220 21	A .49 B .245 25	A .539 B .269 29	A .588 B .294 31
600 x 375 0.225 (2.5) x T.P. SUPPLY N.C. + 6	TOTAL m ³ /s m ³ /s PER SIDE N.C. LEVEL THROW m	A .337 B .168 10	A .393 B .196 14	A .45 B .226 19	A .506 B .253 22	A .562 B .281 26	A .618 B .309 30	A .675 B .337 32
525 x 450 0.236 (2.2) x T.P. SUPPLY N.C. + 5	TOTAL m ³ /s m ³ /s PER SIDE N.C. LEVEL THROW m	A .354 B .177 10	A .413 B .206 14	A .472 B .236 19	A .531 B .265 22	A .59 B .295 26	A .649 B .324 30	A .708 B .354 32
600 x 450 0.27 (2.4) x T.P. SUPPLY N.C. + 6	TOTAL m ³ /s m ³ /s PER SIDE N.C. LEVEL THROW m	A .405 B .202 11	A .472 B .236 15	A .54 B .27 20	A .607 B .303 23	A .675 B .337 27	A .742 B .371 31	A .81 B .405 33
600 x 525 0.315 (3.0) x T.P. SUPPLY N.C. + 7	TOTAL m ³ /s m ³ /s PER SIDE N.C. LEVEL THROW m	A .472 B .236 12	A .551 B .275 16	A .63 B .315 21	A .708 B .354 24	A .787 B .393 28	A .866 B .433 32	A .945 B .472 34

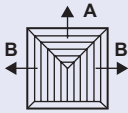
		THREE- WAY BLOW Type DG3															
NECK SIZE AREA m ² RETURN – SP RETURN N.C.	NECK VEL m/s TOTAL PRESSURE Pa	1.5 6		1.75 8		2.0 11		2.25 14		2.5 17		2.75 20		3.0 24			
150 x 150 0.0225 (1.1) x T.P. SUPPLY N.C. + 1	TOTAL m ³ /s m ³ /s PER SIDE N.C. LEVEL THROW m	A .034 .008 1/2	B .013 .013 1.2/3	A .04 .01 1/2.1	B .015 .015 1.4/3	A .045 .011 1.3/2.2	B .017 .017 1.6/3	A .051 .013 1.4/2.3	B .019 .019 1.7/3.4	A .056 .014 1.6/2.4	B .021 .021 2/3.7	A .062 .016 1.6/2.6	B .023 .023 2/4	A .067 .017 1.7/2.9	B .025 .025 2/4		
225 x 225 0.05 (1.2) x T.P. SUPPLY N.C. + 2	TOTAL m ³ /s m ³ /s PER SIDE N.C. LEVEL THROW m	A .075 .019 1.3/2.4	B .028 .028 2/3.4	A .087 .021 1.4/2.6	B .033 .033 2/3.7	A .1 .024 1.6/2.8	B .038 .038 2/4	A .112 .026 1.7/3	B .043 .043 2.2/4.2	A .125 .03 1.8/3	B .047 .047 2.5/4.4	A .135 .034 1.8/3.1	B .050 .050 3/4.6	A .15 .038 1.8/3.3	B .056 .056 3/4.8		
300 x 300 0.09 (1.3) x T.P. SUPPLY N.C. + 4	TOTAL m ³ /s m ³ /s PER SIDE N.C. LEVEL THROW m	A .135 .033 1.5/2.6	B .051 .051 2/4	A .157 .04 1.6/3	B .058 .058 2/4.1	A .18 .045 1.8/3.2	B .067 .067 2/4.2	A .202 .05 1.9/3.5	B .076 .076 2.5/5	A .225 .057 2/3.8	B .084 .084 2.8/5.2	A .247 .063 2/4	B .092 .092 3/5.4	A .27 .069 2.2/4	B .1 .1 3.2/5.8		
375 x 375 0.14 (1.8) x T.P. SUPPLY N.C. + 5	TOTAL m ³ /s m ³ /s PER SIDE N.C. LEVEL THROW m	A .21 .052 1.7/3	B .079 .079 2.8/4.8	A .245 .062 2/3.5	B .091 .091 3/5.2	A .28 .072 2/3.7	B .104 .104 3.2/5.8	A .315 .08 2/4	B .117 .117 3.6/6.2	A .35 .088 2.2/4.3	B .131 .131 4/6.5	A .385 .097 2.4/4.5	B .144 .144 4/6.7	A .42 .105 2.6/4.8	B .157 .157 4.2/7		
450 x 450 0.2025 (2.1) x T.P. SUPPLY N.C. + 6	TOTAL m ³ /s m ³ /s PER SIDE N.C. LEVEL THROW m	A .303 .077 2/3.8	B .113 .113 3/5.2	A .354 .09 2/3.9	B .132 .132 3.2/5.6	A .405 .104 2.2/4	B .150 .150 3.5/6	A .455 .116 2.5/4.5	B .169 .169 4/6.5	A .506 .129 2.6/5	B .188 .188 4.2/7	A .556 .141 2.8/5.2	B .207 .207 4.1/7	A .607 .155 3/5.5	B .226 .226 4.5/7.5		
525 x 525 0.2756 (2.6) x T.P. SUPPLY N.C. + 8	TOTAL m ³ /s m ³ /s PER SIDE N.C. LEVEL THROW m	A .413 .106 2.2/4.2	B .153 .153 3.2/6	A .482 .124 2.3/4.5	B .179 .179 3.6/6	A .55 .138 2.6/5	B .206 .206 4/6.7	A .62 .154 2.8/5.5	B .233 .233 4.2/7	A .689 .174 3/6	B .257 .257 4.4/7.6	A .758 .19 3/6	B .284 .284 4.6/8	A .826 .208 3.2/6	B .309 .309 4.8/8.6		
600 x 600 0.36 (2.7) x T.P. SUPPLY N.C. + 9	TOTAL m ³ /s m ³ /s PER SIDE N.C. LEVEL THROW m	A .54 .14 2.6/4.7	B .200 .200 4/6.5	A .63 .169 3/5	B .230 .230 4/7	A .72 .185 3/5.5	B .267 .267 4/7.2	A .81 .20 3.5/6	B .305 .305 4.5/8	A .9 .228 3.8/6.5	B .336 .336 5/8.5	A .99 .24 4/6.8	B .375 .375 5/9	A 1.08 .274 4/7	B 1.08 .403 5.2/9.5		

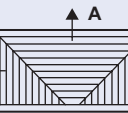
		THREE- WAY BLOW Type DG3L															
NECK SIZE AREA m ² RETURN – SP RETURN N.C.	NECK VEL m/s TOTAL PRESSURE Pa	1.5 6		1.75 8		2.0 11		2.25 14		2.5 17		2.75 20		3.0 24			
300 x 150 0.045 (1.6) x T.P. SUPPLY N.C. + 1	TOTAL m ³ /s m ³ /s PER SIDE N.C. LEVEL THROW m	A .068 .034 2/3	B .017 .017 2/3	A .078 .039 2.1/3.3	B .02 .02 2.1/3.3	A .09 .045 2.3/3.6	B .022 .022 2.3/3.6	A .102 .051 2.4/4	B .025 .025 2.4/4	A .112 .056 2.5/4.2	B .028 .028 2.5/4.2	A .124 .062 2.7/4.4	B .031 .031 2.7/4.4	A .136 .068 3/4.6	B .034 .034 3/4.6		
450 x 225 0.101 (2.0) x T.P. SUPPLY N.C. + 3	TOTAL m ³ /s m ³ /s PER SIDE N.C. LEVEL THROW m	A .151 .077 2.4/4	B .037 .037 2.4/4	A .176 .090 2.7/4.6	B .043 .043 2.7/4.6	A .202 .101 3/5	B .05 .05 3/5	A .227 .113 3/5.3	B .056 .056 3/5.3	A .252 .126 3.2/5.6	B .063 .063 3.2/5.6	A .277 .138 3.3/5.8	B .069 .069 3.3/5.8	A .303 .151 3.5/6	B .075 .075 3.5/6		
600 x 300 0.18 (2.5) x T.P. SUPPLY N.C. + 5	TOTAL m ³ /s m ³ /s PER SIDE N.C. LEVEL THROW m	A .27 .135 3.1/5	B .067 .067 2.9/5	A .315 .157 3.4/5.6	B .078 .078 3.2/5.4	A .36 .18 3.7/7	B .09 .09 3.5/6.9	A .405 .202 3.9/6.4	B .101 .101 3.7/6.2	A .45 .225 4.2/6.7	B .112 .112 4/6.5	A .495 .247 4.4/7.2	B .123 .123 4.2/7	A .54 .274 4.6/7.4	B .135 .135 4.4/7.2		

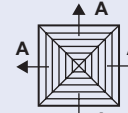
		FOUR- WAY BLOW Type DG4															
NECK SIZE AREA m ² RETURN – SP RETURN N.C.	NECK VEL m/s TOTAL PRESSURE Pa	1.5 6		1.75 8		2.0 11		2.25 14		2.5 17		2.75 20		3.0 24			
150 x 150 0.0225 (1.1) x T.P. SUPPLY N.C. + 1	TOTAL m ³ /s m ³ /s PER SIDE N.C. LEVEL THROW m	A .034 .008 1/2	B .013 .013 1.2/3	A .04 .01 1.1/2.1	B .015 .015 1.4/3	A .045 .011 1.3/2.2	B .017 .017 1.6/3	A .051 .013 1.4/2.3	B .019 .019 1.7/3.4	A .056 .014 1.6/2.4	B .021 .021 2/3.7	A .062 .016 1.6/2.6	B .023 .023 2/4	A .067 .017 1.7/2.9	B .025 .025 2/4		
225 x 225 0.05 (1.2) x T.P. SUPPLY N.C. + 2	TOTAL m ³ /s m ³ /s PER SIDE N.C. LEVEL THROW m	A .075 .019 1.3/2.4	B .028 .028 2/3.4	A .087 .021 1.4/2.6	B .033 .033 2/3.7	A .1 .024 1.6/2.8	B .038 .038 2/4	A .112 .026 1.7/3	B .043 .043 2.2/4.2	A .125 .03 1.8/3	B .047 .047 2.5/4.4	A .135 .034 1.8/3.1	B .050 .050 3/4.6	A .15 .038 1.8/3.3	B .056 .056 3/4.8		
300 x 300 0.09 (1.3) x T.P. SUPPLY N.C. + 4	TOTAL m ³ /s m ³ /s PER SIDE N.C. LEVEL THROW m	A .135 .033 1.5/2.6	B .051 .051 2/4	A .157 .04 1.6/3	B .058 .058 2/4.1	A .18 .045 1.8/3.2	B .067 .067 2/4.2	A .202 .05 1.9/3.5	B .076 .076 2.5/5	A .225 .057 2/3.8	B .084 .084 2.8/5.2	A .247 .063 2/4	B .092 .092 3/5.4	A .27 .069 2.2/4	B .1 .1 3.2/5.8		
375 x 375 0.14 (1.8) x T.P. SUPPLY N.C. + 5	TOTAL m ³ /s m ³ /s PER SIDE N.C. LEVEL THROW m	A .21 .052 1.7/3	B .079 .079 2.8/4.8	A .245 .062 2/3.5	B .091 .091 3/5.2	A .28 .072 2/3.7	B .104 .104 3.2/5.8	A .315 .08 2/4	B .117 .117 3.6/6.2	A .35 .088 2.2/4.3	B .131 .131 4/6.5	A .385 .097 2.4/4.5	B .144 .144 4/6.7	A .42 .105 2.6/4.8	B .157 .157 4.2/7		
450 x 450 0.2025 (2.1) x T.P. SUPPLY N.C. + 6	TOTAL m ³ /s m ³ /s PER SIDE N.C. LEVEL THROW m	A .303 .077 2/3.8	B .113 .113 3/5.2	A .354 .09 2/3.9	B .132 .132 3.2/5.6	A .405 .104 2.2/4	B .150 .150 3.5/6	A .455 .116 2.5/4.5	B .169 .169 4/6.5	A .506 .129 2.6/5	B .188 .188 4.2/7	A .556 .141 2.8/5.2	B .207 .207 4.1/7	A .607 .155 3/5.5	B .226 .226 4.5/7.5		
525 x 525 0.2756 (2.6) x T.P. SUPPLY N.C. + 8	TOTAL m ³ /s m ³ /s PER SIDE N.C. LEVEL THROW m	A .413 .106 2.2/4.2	B .153 .153 3.2/6	A .482 .124 2.3/4.5	B .179 .179 3.6/6	A .55 .138 2.6/5	B .206 .206 4/6.7	A .62 .154 2.8/5.5	B .233 .233 4.2/7	A .689 .174 3/6	B .257 .257 4.4/7.6	A .758 .19 3/6	B .284 .284 4.6/8	A .826 .208 3.2/6	B .309 .309 4.8/8.6		
600 x 600 0.36 (2.7) x T.P. SUPPLY N.C. + 9	TOTAL m ³ /s m ³ /s PER SIDE N.C. LEVEL THROW m	A .54 .14 2.6/4.7	B .200 .200 4/6.5	A .63 .169 3/5	B .230 .230 4/7	A .72 .185 3/5.5	B .267 .267 4/7.2	A .81 .20 3.5/6	B .305 .305 4.5/8	A .9 .228 3.8/6.5	B .336 .336 5/8.5	A .99 .24 4/6.8	B .375 .375 5/9	A 1.08 .274 4/7	B 1.08 .403 5.2/9.5		

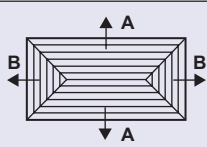

FOUR-WAY BLOW Type DG4L

NECK SIZE AREA m ² RETURN – SP RETURN N.C.	NECK VEL m/s TOTAL PRESSURE Pa	1.5 6	1.75 8	2.0 11	2.25 14	2.5 17	2.75 20	3.0 24
225 x 150 0.0337 (1.2) x T.P. SUPPLY N.C. + 0	TOTAL m ³ /s m ³ /s PER SIDE N.C. LEVEL THROW m	A .052 B .018 .008 1.5/2.8 , 1/2	A .06 B .02 .01 1.7/3 , 1/2.1	A .068 B .023 .011 10 2/3.4 , 1.3/2.2	A .076 B .025 .013 14 2.1/3.6 , 1.4/2.3	A .084 B .028 .014 17 2.2/4 , 1.6/2.4	A .092 B .03 .016 20 2.3/4.1 , 1.6/2.6	A .10 B .033 .017 23 2.5/4.3 , 1.7/2.9
300 x 150 0.045 (1.6) x T.P. SUPPLY N.C. + 1	TOTAL m ³ /s m ³ /s PER SIDE N.C. LEVEL THROW m	A .068 B .026 .008 2.1/3.7 , 1/2	A .078 B .029 .01 2.2/4 , 1/2.1	A .09 B .034 .011 11 2.4/4.3 , 1.3/2.2	A .102 B .038 .013 15 2.6/4.6 , 1.4/2.3	A .112 B .042 .014 18 2.8/5 , 1.6/2.4	A .124 B .046 .016 21 2.9/5.1 , 1.6/2.6	A .136 B .051 .017 24 3/5.2 , 1.7/2.9
375 x 150 0.0562 (1.9) x T.P. SUPPLY N.C. + 1	TOTAL m ³ /s m ³ /s PER SIDE N.C. LEVEL THROW m	A .084 B .034 .008 2/4 , 1/2	A .098 B .039 .01 2.2/4.2 , 1/2.1	A .112 B .045 .011 12 2.4/4.6 , 1.3/2.2	A .126 B .05 .013 15 2.6/5 , 1.4/2.3	A .14 B .056 .014 19 2.8/5.2 , 1.6/2.4	A .154 B .061 .016 23 3/5.4 , 1.6/2.6	A .168 B .067 .017 25 3/5.8 , 1.7/2.9
450 x 150 0.0675 (2.6) x T.P. SUPPLY N.C. + 2	TOTAL m ³ /s m ³ /s PER SIDE N.C. LEVEL THROW m	A .101 B .042 .008 2.7/4.5 , 1/2	A .118 B .049 .01 2.8/4.7 , 1/2.1	A .135 B .056 .011 13 2.9/5 , 1.3/2.2	A .151 B .062 .013 16 3/5.5 , 1.4/2.3	A .168 B .07 .014 20 3/6 , 1.6/2.4	A .185 B .076 .016 24 3/6 , 1.6/2.6	A .202 B .085 .017 26 3.2/6.3 , 1.7/2.9
525 x 150 0.0787 (3.0) x T.P. SUPPLY N.C. + 3	TOTAL m ³ /s m ³ /s PER SIDE N.C. LEVEL THROW m	A .118 B .051 .008 2.8/5 , 1/2	A .137 B .058 .01 3/5.3 , 1/2.1	A .157 B .067 .011 13 3.2/5.6 , 1.4/2.3	A .177 B .075 .013 16 3.5/6 , 1.4/2.3	A .196 B .084 .014 20 4.6/6 , 1.6/2.4	A .216 B .092 .016 24 4/6.8 , 1.6/2.6	A .236 B .101 .017 26 4.2/7 , 1.7/2.9
600 x 150 0.09 (4.0) x T.P. SUPPLY N.C. + 4	TOTAL m ³ /s m ³ /s PER SIDE N.C. LEVEL THROW m	A .135 B .059 .008 2.8/5 , 1/2	A .157 B .068 .01 3/5.3 , 1/2.1	A .18 B .079 .011 14 3.2/5.6 , 1.4/2.3	A .202 B .088 .013 17 3.5/6 , 1.4/2.3	A .225 B .098 .014 21 4.6/6 , 1.6/2.4	A .247 B .107 .016 25 4/6.8 , 1.6/2.6	A .27 B .119 .017 27 4.2/7 , 1.7/2.9
300 x 225 0.0675 (1.4) x T.P. SUPPLY N.C. + 2	TOTAL m ³ /s m ³ /s PER SIDE N.C. LEVEL THROW m	A .10 B .031 .019 1.8/3.4 , 1.3/2.4	A .118 B .038 .021 2/3.6 , 1.4/2.6	A .135 B .043 .024 13 2/4 , 1.6/2.8	A .151 B .049 .026 16 2/4.2 , 1.7/3	A .168 B .054 .03 20 2.2/4.4 , 1.8/3	A .185 B .058 .034 24 2.6/4.8 , 1.8/3.1	A .202 B .063 .038 26 2.8/5 , 1.8/3.3
375 x 225 0.0843 (1.6) x T.P. SUPPLY N.C. + 3	TOTAL m ³ /s m ³ /s PER SIDE N.C. LEVEL THROW m	A .126 B .044 .019 2.7/4.5 , 1.3/2.4	A .147 B .052 .021 2.8/4.7 , 1.4/2.6	A .168 B .06 .024 14 2.9/5 , 1.6/2.8	A .189 B .068 .026 17 3/5.5 , 1.7/3	A .21 B .075 .03 21 3/6 , 1.8/3	A .231 B .081 .034 25 3.6 , 1.8/3.1	A .252 B .088 .038 27 3.2/6.3 , 1.8/3.3
450 x 225 0.101 (2.0) x T.P. SUPPLY N.C. + 3	TOTAL m ³ /s m ³ /s PER SIDE N.C. LEVEL THROW m	A .151 B .056 .019 2.8/5 , 1.3/2.4	A .176 B .067 .021 3/5.3 , 1.4/2.6	A .202 B .077 .024 15 3.2/5.6 , 1.6/2.8	A .227 B .087 .026 18 3.5/6 , 1.7/3	A .252 B .096 .03 22 4/6.6 , 1.8/3	A .277 B .104 .034 26 4/6.8 , 1.8/3.1	A .303 B .113 .038 28 4.2/7 , 1.8/3.3
525 x 225 0.118 (2.2) x T.P. SUPPLY N.C. + 4	TOTAL m ³ /s m ³ /s PER SIDE N.C. LEVEL THROW m	A .177 B .069 .019 3/5.4 , 1.3/2.4	A .206 B .082 .021 3.2/5.5 , 1.4/2.6	A .236 B .094 .024 15 3.5/6 , 1.6/2.8	A .265 B .106 .026 18 3.8/6.5 , 1.7/3	A .295 B .117 .03 22 4/7 , 1.8/3	A .324 B .128 .034 26 4.1/7.5 , 1.8/3.1	A .354 B .139 .038 28 4.3/8 , 1.8/3.3
600 x 225 0.135 (2.7) x T.P. SUPPLY N.C. + 4	TOTAL m ³ /s m ³ /s PER SIDE N.C. LEVEL THROW m	A .202 B .082 .019 3/5.4 , 1.3/2.4	A .236 B .097 .021 3.2/5.5 , 1.4/2.6	A .27 B .111 .024 16 3.5/6 , 1.6/2.8	A .303 B .125 .026 19 3.8/6.5 , 1.7/3	A .337 B .138 .03 23 4/7 , 1.8/3	A .371 B .151 .034 27 4.1/7.5 , 1.8/3.1	A .405 B .164 .038 29 4.3/8 , 1.8/3.3
375 x 300 0.112 (1.8) x T.P. SUPPLY N.C. + 2	TOTAL m ³ /s m ³ /s PER SIDE N.C. LEVEL THROW m	A .168 B .051 .033 2/4 , 1.5/2.6	A .196 B .058 .04 2.2/4.2 , 1.6/3	A .224 B .067 .045 16 2.4/4.6 , 1.8/3.2	A .252 B .076 .05 19 2.6/5 , 1.9/3.5	A .28 B .083 .057 23 2.8/5.2 , 2/3.8	A .308 B .091 .063 27 3/5.4 , 2/4	A .336 B .099 .069 29 3/5.8 , 2.2/4
450 x 300 0.135 (1.8) x T.P. SUPPLY N.C. + 3	TOTAL m ³ /s m ³ /s PER SIDE N.C. LEVEL THROW m	A .202 B .068 .033 2.8/5 , 1.5/2.6	A .236 B .078 .04 3/5.3 , 1.6/3	A .27 B .09 .045 17 3.2/5.6 , 1.8/3.2	A .303 B .101 .05 20 3.5/6 , 1.9/3.5	A .337 B .111 .057 24 4/6.6 , 2/3.8	A .371 B .122 .063 28 4/6.8 , 2/4	A .405 B .133 .069 30 4.2/7 , 2.2/4
525 x 300 0.157 (2.0) x T.P. SUPPLY N.C. + 5	TOTAL m ³ /s m ³ /s PER SIDE N.C. LEVEL THROW m	A .235 B .084 .033 3/5.4 , 1.5/2.6	A .274 B .097 .04 3.2/5.5 , 1.6/3	A .314 B .112 .045 17 3.5/6 , 1.8/3.2	A .353 B .126 .05 20 3.8/6.5 , 1.9/3.5	A .392 B .139 .057 24 4/7 , 2/3.8	A .431 B .152 .063 28 4.1/7.5 , 2/4	A .471 B .166 .069 30 4.3/8 , 2.2/4
600 x 300 0.18 (2.5) x T.P. SUPPLY N.C. + 5	TOTAL m ³ /s m ³ /s PER SIDE N.C. LEVEL THROW m	A .27 B .102 .033 3.4/6 , 1.5/2.6	A .315 B .117 .04 3.6/6.5 , 1.6/3	A .36 B .135 .045 18 4/7 , 1.8/3.2	A .405 B .152 .05 21 4/7.5 , 1.9/3.5	A .45 B .168 .057 25 4.3/8 , 2/3.8	A .495 B .184 .063 29 4.7/8.5 , 2/4	A .54 B .201 .069 31 5/9 , 2.2/4
450 x 375 0.168 (2.0) x T.P. SUPPLY N.C. + 4	TOTAL m ³ /s m ³ /s PER SIDE N.C. LEVEL THROW m	A .252 B .074 .052 2.7/4.5 , 1.7/3	A .294 B .085 .062 2.8/4.7 , 2/3.5	A .336 B .096 .072 18 2.9/5 , 2/3.7	A .378 B .109 .08 21 3/5.5 , 2/4	A .42 B .122 .088 25 3/6 , 2.2/4.3	A .462 B .134 .097 29 3/6 , 2.4/4.5	A .504 B .147 .105 31 3.2/6.3 , 2.6/4.8
525 x 375 0.196 (2.1) x T.P. SUPPLY N.C. + 5	TOTAL m ³ /s m ³ /s PER SIDE N.C. LEVEL THROW m	A .294 B .095 .052 3.4/6 , 1.7/3	A .343 B .109 .062 3.6/6.5 , 2/3.5	A .392 B .124 .072 18 4/7 , 2/3.7	A .441 B .14 .08 21 4/7.5 , 2/4	A .49 B .157 .088 25 4.3/8 , 2.2/4.3	A .539 B .172 .097 29 4.7/8.5 , 2.4/4.5	A .588 B .189 .105 31 5/9 , 2.6/4.8
600 x 375 0.225 (2.5) x T.P. SUPPLY N.C. + 6	TOTAL m ³ /s m ³ /s PER SIDE N.C. LEVEL THROW m	A .337 B .116 .052 10 3.4/6 , 1.7/3	A .393 B .134 .062 14 3.6/6.5 , 2/3.5	A .45 B .153 .072 19 4/7 , 2/3.7	A .506 B .173 .08 22 4/7.5 , 2/4	A .562 B .193 .088 26 4.3/8 , 2.2/4.3	A .618 B .212 .097 30 4.7/8.5 , 2.4/4.5	A .675 B .232 .105 32 5/9 , 2.6/4.8
525 x 450 0.236 (2.2) x T.P. SUPPLY N.C. + 5	TOTAL m ³ /s m ³ /s PER SIDE N.C. LEVEL THROW m	A .354 B .1 .077 10 2.8/5 , 2/3.8	A .413 B .116 .09 14 3/5.3 , 2/3.9	A .472 B .132 .104 19 3.2/5.6 , 2.2/4	A .531 B .149 .116 22 3.5/6 , 2.5/4.5	A .59 B .166 .129 26 4/6.6 , 2.6/5	A .649 B .183 .141 30 4/6.8 , 2.8/5.2	A .708 B .199 .155 32 4.2/7 , 3/5.5
600 x 450 0.27 (2.4) x T.P. SUPPLY N.C. + 6	TOTAL m ³ /s m ³ /s PER SIDE N.C. LEVEL THROW m	A .405 B .125 .077 11 3.5/6.5 , 2/3.8	A .472 B .146 .09 15 3.7/7 , 2/3.9	A .54 B .166 .104 20 4/7.4 , 2.2/4	A .607 B .187 .116 23 4.2/8 , 2.5/4.5	A .675 B .208 .129 27 4.5/8.4 , 2.6/5	A .742 B .23 .141 31 4.7/8.6 , 2.8/5.2	A .81 B .25 .155 33 5/9 , 3/5.5
600 x 525 0.315 (3.0) x T.P. SUPPLY N.C. + 7	TOTAL m ³ /s m ³ /s PER SIDE N.C. LEVEL THROW m	A .472 B .13 .106 12 3/5.4 , 2.2/4.2	A .551 B .151 .124 16 3.2/5.5 , 2.3/4.5	A .63 B .177 .138 21 3.5/6 , 2.6/5	A .708 B .2 .154 24 3.8/6.5 , 2.8/5.5	A .787 B .219 .174 28 4/7 , 3/6	A .866 B .243 .19 32 4.1/7.5 , 3/6	A .945 B .264 .208 34 4.3/8 , 3.2/6



Ordering Specification

Diffuser

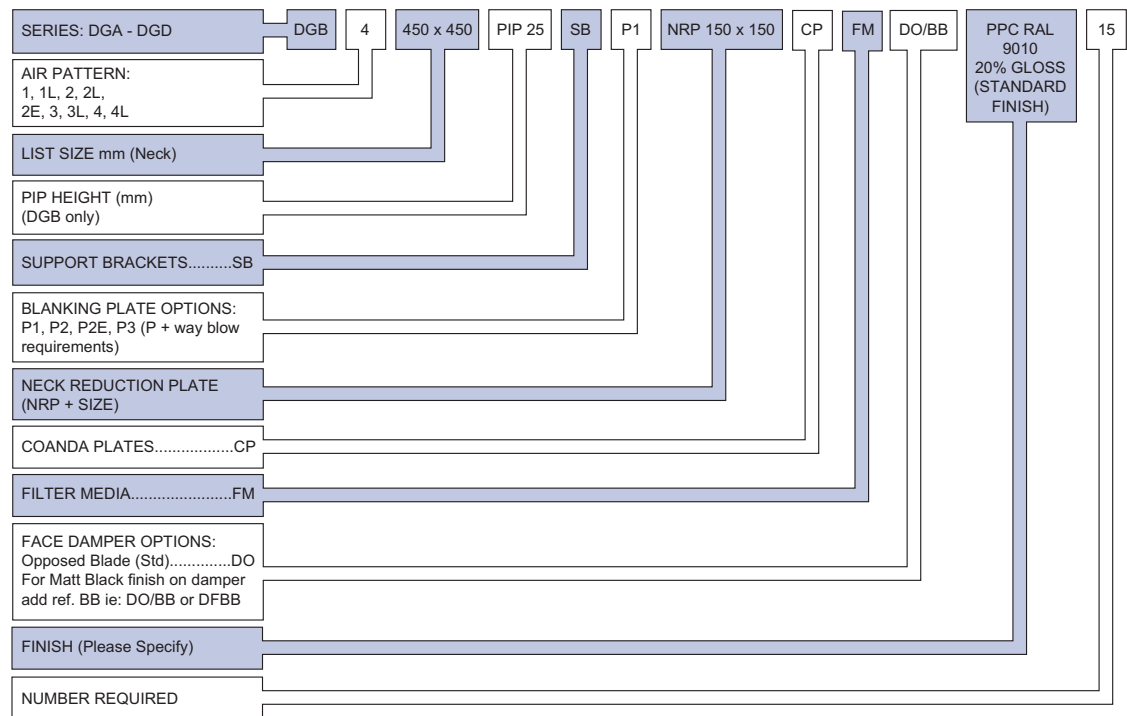

LIST SIZE RANGE

Type	DGA	150 x 150 up to
	DGC	600 x 600
	DGD	in 75mm increments
Type	DGB	450 x 450 only (600 O/A)

FIXING

Diffuser only (solid duct connection):
 Drill & rivet through diffuser neck
 Diffuser with Plenum: (flexible duct connection)
 Standard support is via drop rods (by others) to slots on diffuser plenum

FINISH

Standard Finish:
 Standard finish for all units is a PPC White RAL 9010 20% gloss.
 Special Finish:
 PPC to stock BS or RAL colour.

Dampers: Mill Finish Aluminium or Galvanised Steel

SUPPORT BRACKETS

Fitted to diffuser for drop rod fixing on units without plenum connection box.

BLANKING PLATES

Clip on quarter core blanking available to modify air pattern on 4 way diffuser:
 P1 = 4 Way Down to 1 Way
 P2 = 4 Way Down to 2 Way
 P2E = 4 Way Down to 2 Way corner
 P3 = 4 Way Down to 3 Way

NECK REDUCTION PLATES

Fitted to diffuser neck to reduce inlet size and maintain diffuser performance.

COANDA PLATES

Fitted to diffuser border to maintain ceiling effect.

SERIES DG

Louvred Face Ceiling Diffusers

Ordering Specification

Plenum

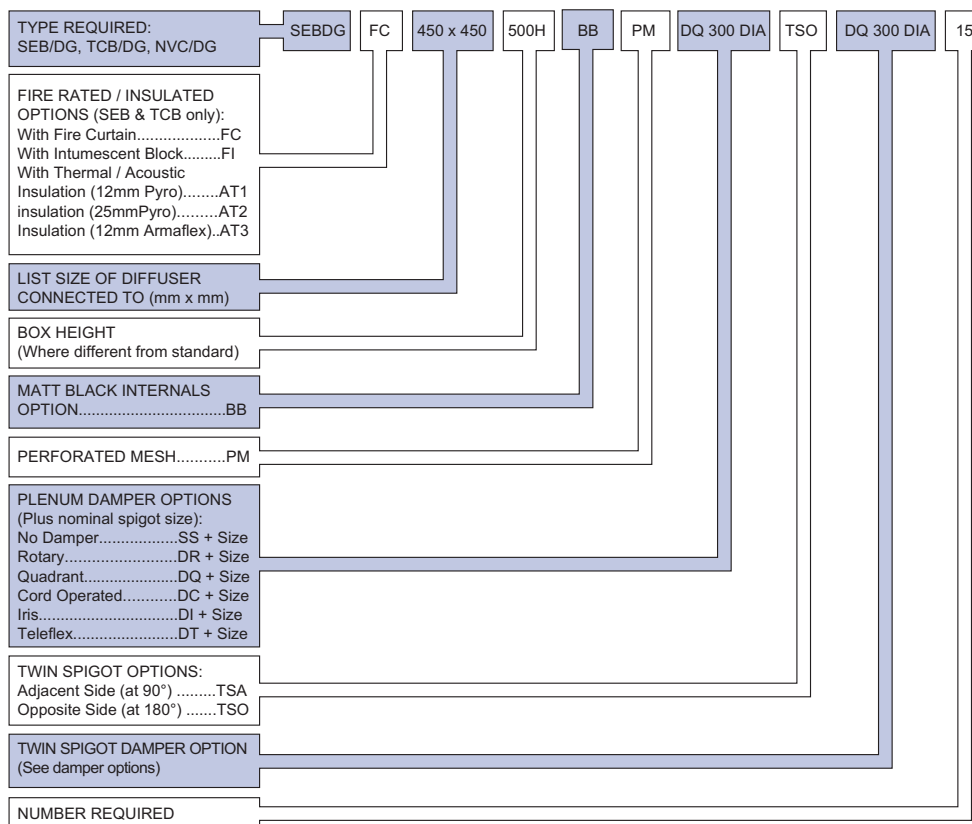

GENERAL SPECIFICATION

0.7mm Galvanised or Zintec coated mild steel plenum. Spigot Construction: Standard size spigots use plastic clip-in spigots. Non standard a sealed screw in spigot.

PLENUM FITTING

Plenum boxes are typically supplied loose, however some diffuser models, for design and handling purposes, may be supplied with the plenum factory fitted. The popular 450sq unit is typically supplied with the box attached

FIRE RATED PLENUM OPTION

Fire Curtain - (FC) : Plenum fitted with curtain fire damper
Intumescent - (FI) : Plenum fitted with intumescent fire damper.
(see fire rated plenum datasheet for details).

THERMAL/ACOUSTIC INSULATION

Plenum box fully lined with 12 or 25mm black pyrosorb thermal & acoustic lining or 12mm Armaflex lining.

PERFORATED MESH

Plenum fitted internally with 50% perforated equalising mesh.

GILBERTS

Head Office and Works
GILBERTS (BLACKPOOL) LTD
 Gilair Works, Clifton Road,
 Blackpool.
 Lancashire FY4 4QT.
 Telephone: (01253) 766911
 Fax: (01253) 767941
 e-mail: sales@gilbertsblackpool.com
 Web: www.gilbertsblackpool.com

