

Article group
1.51



04/2008

Vario

Door air curtains

**Innovative,
professional,
international**

In over 35 years, Kampmann GmbH has grown from being a family-led company to become an internationally

renowned group of companies. Kampmann systems for heating, cooling and ventilation are today market leaders in a number of different market sectors. Innovation and the highest standards of quality guarantee this success into the future.

We have an "ear on the market" and the knowledge and expertise gained from 35 years of experience in development, production and sales. This, combined with a professionally-manned research and development department, is the basis for our continuous product development. This is what allows us to provide our customers with the best technical product at any time.

Traditionally, Kampmann's skills and expertise have been in the production of standard products with an extraordinary range of adapted products, as well as in the production of technically and visually high-quality tailor-made design solutions. Our specialist staff deal with the building in its entirety and develop unique and efficient system solutions. Our entire range is reflected in mix of standard, non-standard and tailor-made products for project-orientated solutions.

We set ourselves very high standards in production. Today an exceptionally well-trained specialist workforce manufactures high-quality Kampmann products in three plants for customers throughout the world. A number of different certificates are evidence of our high standards of quality, which have become the standard at Kampmann. Our products are characterised by the high guaranteed DIN EN-tested heat outputs. In terms of quality management the requirements of TÜV certification according to DIN EN ISO 9001 have been met since 1996.

For decades, Kampmann customers have valued our excellent service. Local external engineers and technicians, in-house measuring engineers and the Kampmann customer service team are available to customers. Kampmann good air quality is now to be found across the globe. Our sales engineers now cover the whole of Germany and Europe.

This Vario Door air curtain brochure provides you with an insight into our wide product range. Take a look and make up your own mind – do not hesitate to arrange a personal visit with us. It is our aim to meet your high quality expectations, right down to the last detail.

Well-being is our product – Quality is our benchmark!

Hendrik Kampmann
Managing Director



Peter Kaß
Managing Director



Door air curtains Production in the Kampmann works in

Lingen

Friedrich-Ebert-Straße 128-130

49811 Lingen (Ems)

Tel. +49 591 7108-0

Fax +49 591 7108-300



Vario Door air curtains - For the controlled screening of open doorways

Basic units, Casings

Accessories

Contents

Article group 1.51 Vario Door air curtains



Product description/Accessories

For the controlled screening of open doorways.....	4
Basic units	5
Overview of types	6
Casings • Casing extensions	7
Brackets	8
Steel accessories	9

Product description/
Accessories



Controls

Fan control • Wiring • Remote radio control.....	10
Cabling.....	11
Accessories: 3- and 5-stage switches • Cascade module.....	12
Accessories: Control valves • Frost protection thermostat	13
BUS-controller with the KaBUS ECO system	14-15

Controls

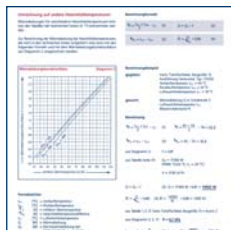

Design information

Selection process	16
Suggested layout.....	17
Unit selection • Combined options	18
Layout • Limits of use • Frost protection • Low temperature operation • Sound pressure levels.....	19
Conversion to other flow and return temperatures.....	20
Water pressure	21

Design information



Technical data

Dimensions of steel metal accessories, horizontal and vertical models	22
Horizontal dimensions	23-24
Vertical dimensions	25-26
Standing dimensions	27-28
Dimensions of model sizes 10, 15, 20, 25; version without heat exchanger, horizontal	29
Heat outputs	30-35
Unit data model sizes 10, 15, 20, 25; version without heat exchanger, horizontal	36

Technical data

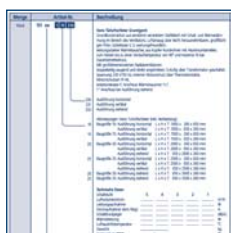

Specifications / Ordering

Vario door air curtain basic units	37
Basic unit casings • Casing extensions	38
Brackets • Steel metal accessories for installation in suspended ceilings	39
Controls accessories	40-42
Vario door air curtains for use with cold stores	43
Order form	45
Your KAMPMANN contact	46

Specifications/
Ordering

Printed on environmentally-friendly, non-chlorine bleached paper; all rights reserved; reproductions, even of excerpts, are only possible with the express authorisation of Kampmann. We reserve the right to make modifications, edition 297/04/08/40 GB



Open doorways

are nowadays an integral part of the "shopping" leisure experience. By removing the "obstacle of a doorway", passers-by and potential customers are motivated to enter the retail space. The usable retail floor area is thereby extended and the inviting open entrance area with an unimpeded view of the range of products results in higher numbers of customers.

Door air curtains create a comfortable interior environment during the heating season by screening open doorways. Customers can enjoy entering the entrance area of the store.

The warm stream of air that can be felt creates a rapid feeling of comfort and cosiness, especially when the temperatures outside are low, and has the benefit over units that blow from below that dust and clothing is not blown up.

Vario door air curtains – now with a new attractive casing that is simple and easy to fit

- Filter change without using a tool
- Modular construction means that several units visually look like a single unit
- Can be installed within a suspended ceiling or with a bespoke casing

Vario door air curtains can also be controlled with a remote radio controller!

Vario door air curtains for use in shops, boutiques, malls, bakeries that open onto the street, supermarkets, public buildings with discharge heights of between 2.3 and 3.0 m.

Kampmann door air curtains mean that the warm air stays where it should: inside the building

Minimizes energy losses by screening out cold air:

- Continuous filtration of inlet air, thereby reducing the ingress of dirt from the street
- Fewer draughts: work stations can be positioned closer to the entrance area, and the sales floor area can be better used.
- Works with air conditioning systems in summer when run without the supply of warm water; reduces the entry of warm outside air, lowers the cooling outputs and energy costs
- Utilises accumulated air at ceiling level to provide a screening curtain of air
- Rapid warm-up after long periods of cooling thanks to the high air volumes produced by the door air curtains
- Many uses in shops of all types, malls and public buildings
- Wide range of fixing and controls accessories





Installed within a suspended ceiling with curved air outlet (non-standard model)

Basic units

Vario door air curtains basic units are available in different models to meet every possible installation requirement.

Vario door air curtains have a fan group that draws the air through the dry layer filter and the high-output heat exchanger. The inclined motor base plate separates the induction and pressure side and, on the pressure side, it has an outlet angle to accommodate the leaving air rectifier or to connect to other sheet steel components.

- Made of sheet steel with sound and heat insulation on the inside
- Basic unit without casing is operational and can be encased on site without any loss of output
- Large radial fans, direct-driven by 1-stage condenser motor that can be switched between 5 fan speeds by an integral transformer
- Voltage 230 V/50 Hz
- Easily removable air filter (Filter class G2 according to DIN EN 779), fixed to a grille frame; can be cleaned by vacuuming or washing
- Heat exchanger made of hollow copper pipes with aluminium fins, suitable for use with LPHW heating medium up to a temperature of max. 90 °C, maximum permissible continuous operating pressure 10 bar
- Refer to Dimensions and Technical Data for nominal connection widths

Basic unit models based on installation position:

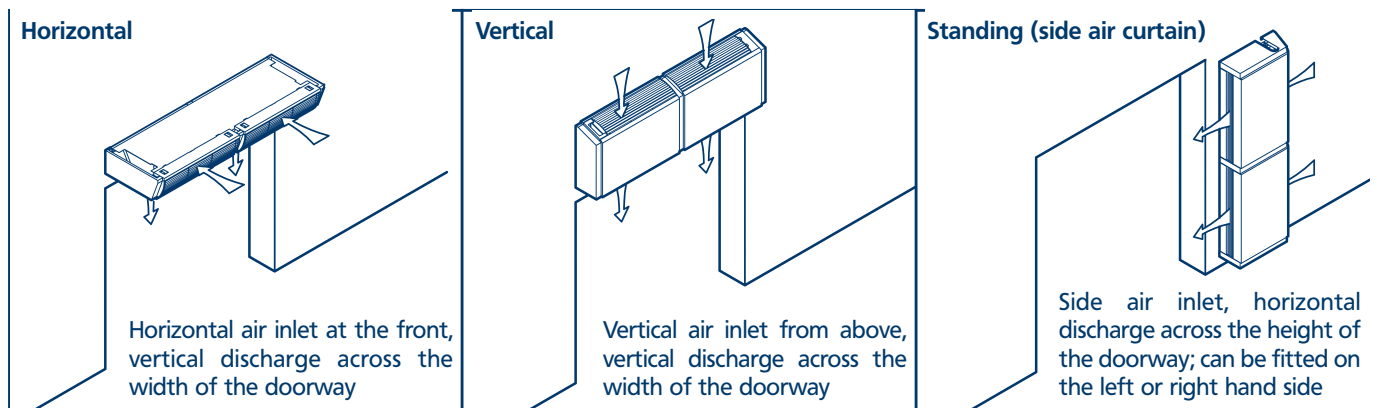

Possible installation positions:

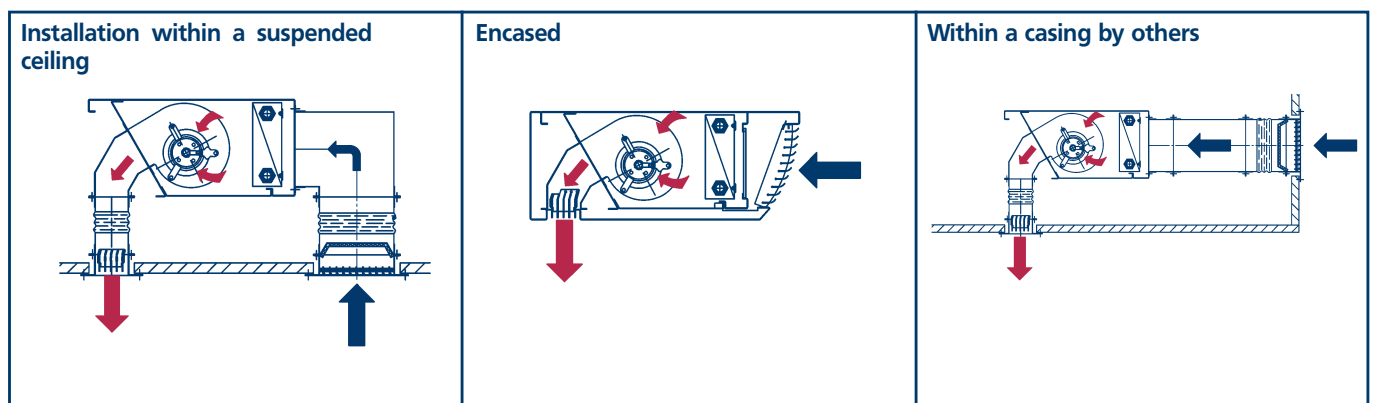

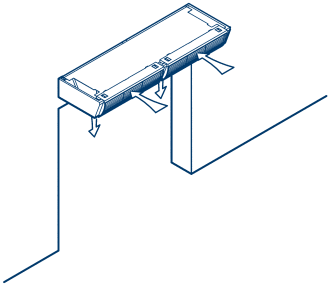
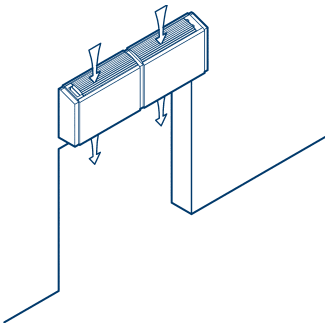
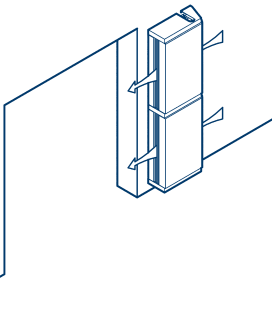
Vario Door air curtains - Overview of types				Type key	
				Vario, model size 25, basic unit, horizontal 1 25 330	
$H_{max.}^{1), W_{max.}^{1), 2)}$	2,3 - 3,0				
Model	Air volume m ³ /h	Max. door width m	Model size		
horizontal 	660 - 1390	1.0	10		
	930 - 2130	1.5	15		
	1210 - 2820	2.0	20		
	1660 - 4000	2.5	25		
	Horizontal basic unit Basic unit casing Casing extension Replacement filter for basic unit			330 800 810 825	330
vertical 	600 - 1390	1.0	10		
	930 - 2130	1.5	15		
	1210 - 2820	2.0	20		
	1660 - 4000	2.5	25		
	Horizontal basic unit Basic unit casing Casing extension Replacement filter for basic unit			331 801 811 825	801
standing (side air stream) 	1210 - 2820	2,0	20		
	1660 - 4000	2,5	25		
	1860 - 4260	3,0	30		
	2140 - 4950	3,5	35		
	Horizontal basic unit Basic unit casing Replacement filter for basic unit			332 802 825	802
				25	
				25	
				25	

¹⁾ $H_{max.}$ = Max. discharge height (horizontal and vertical models),
 $W_{max.}$ = Max. discharge width (standing model), with average to good pressure conditions/requirements/environment, see pages 16 and 17

²⁾ We recommend installing a door air curtain on both sides of the doorway if the maximum discharge width is exceeded.

Article no. for DataNorm/EDV entry:
151 000 (insert type)

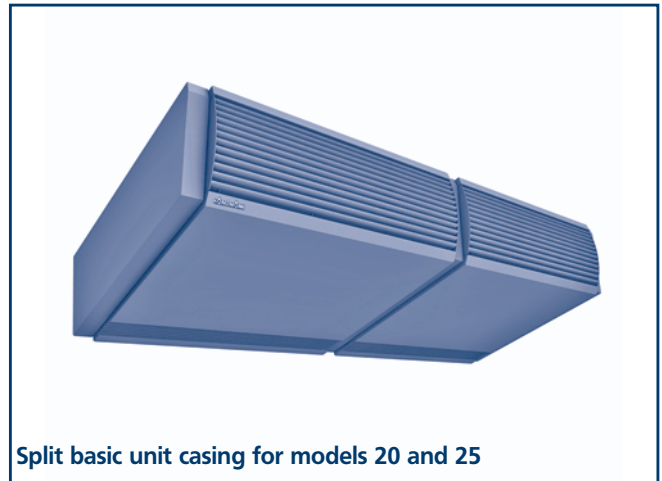
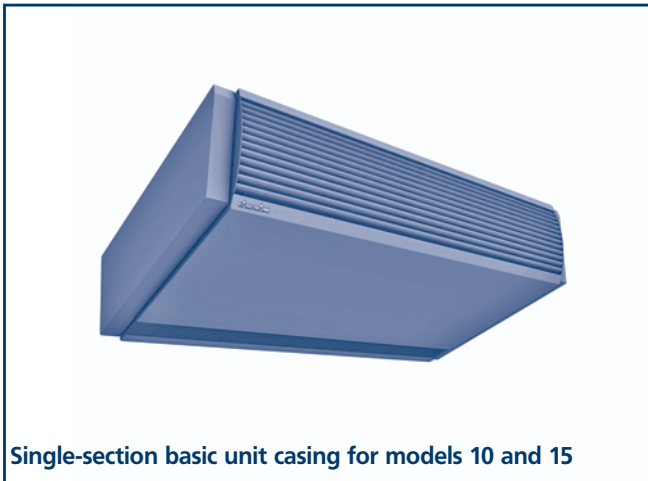

Casings • Casing extensions

- Attractive slimline housing design
- Simple to fit
- Stable steel metal construction
- Welded and smoothed corners, with side, recessed end sections that can easily be removed for service and maintenance
- Powdercoated traffic white RAL 9016
- Inlet air grille, rounded linear shape, made of a droplet profile that enhances the air flow, powdercoated RAL 9006, easy to remove for filter inspection
- Leaving air rectifier in the outlet air stream for minimum turbulence and even outlet air flow, powdercoated RAL 9006
- Unit lengths of > 2.5 m (horizontal and vertical models) are possible with casing extensions (modular construction)

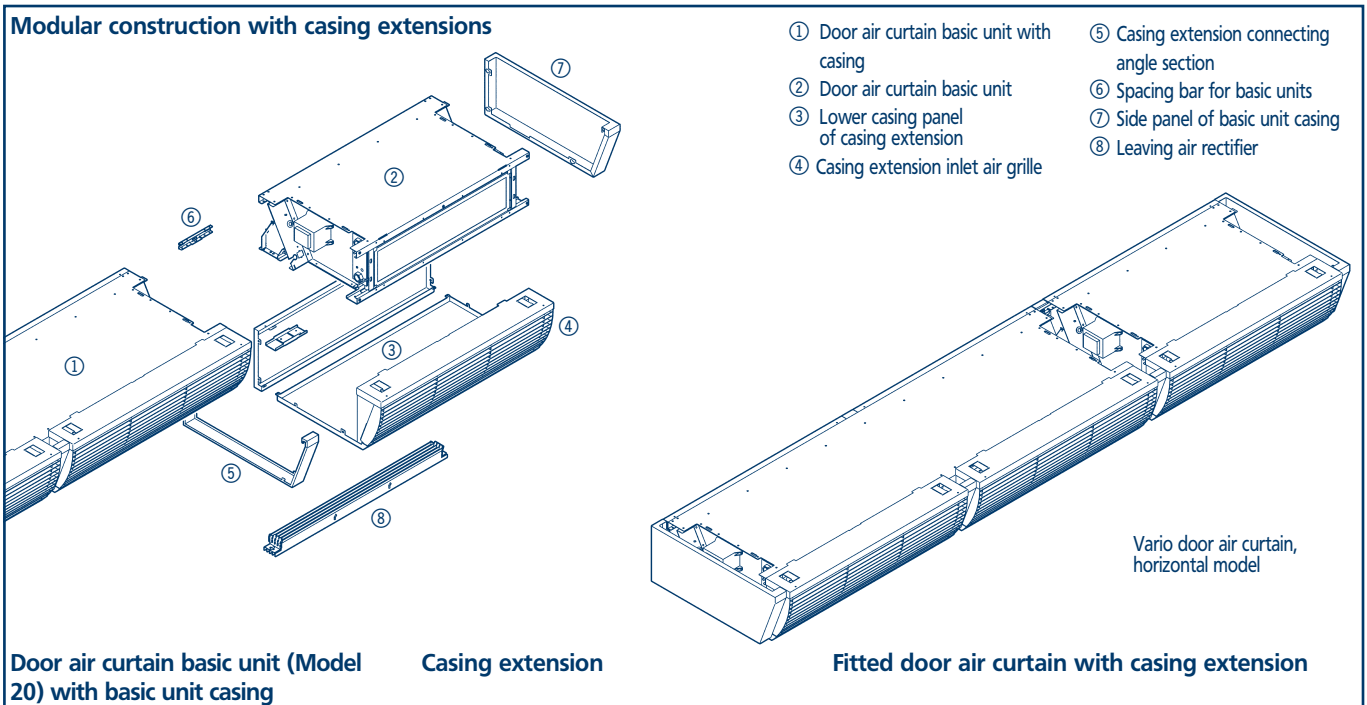

Wall brackets · Ceiling brackets

- For installing horizontal and vertical units
- Adjustable towards and from the door
- Brackets powdercoated traffic white RAL 9016
- Exact height adjustment by shortening the threaded rods

Product description / Accessories

Telescopic fixing with wall and ceiling brackets

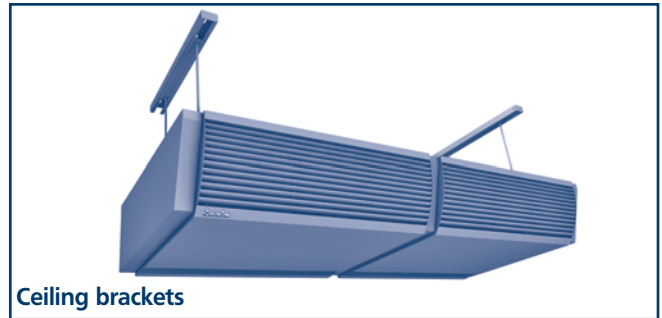
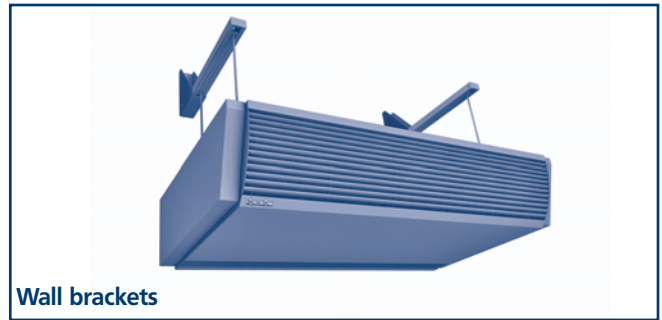
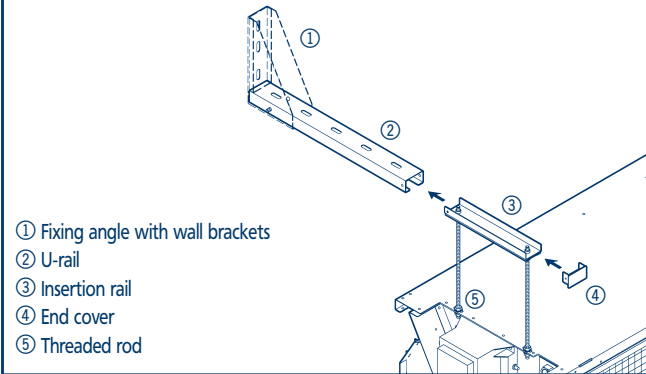

Overview of brackets/Dimensions

Model	horizontal	vertical	standing
Wall brackets			
Vario door air curtain	Wall brackets Type 100890	Wall brackets Type 100891	
Ceiling brackets			
Vario door air curtain	Ceiling brackets Type 100895	Ceiling brackets Type 100896	

Supplied as standard with longitudinal openings for fixing with screws and rawplugs to the wall or a substructure on site

Article no. for DataNorm/EDV entry: 151 000 _ (Insert type)

Sheet steel components

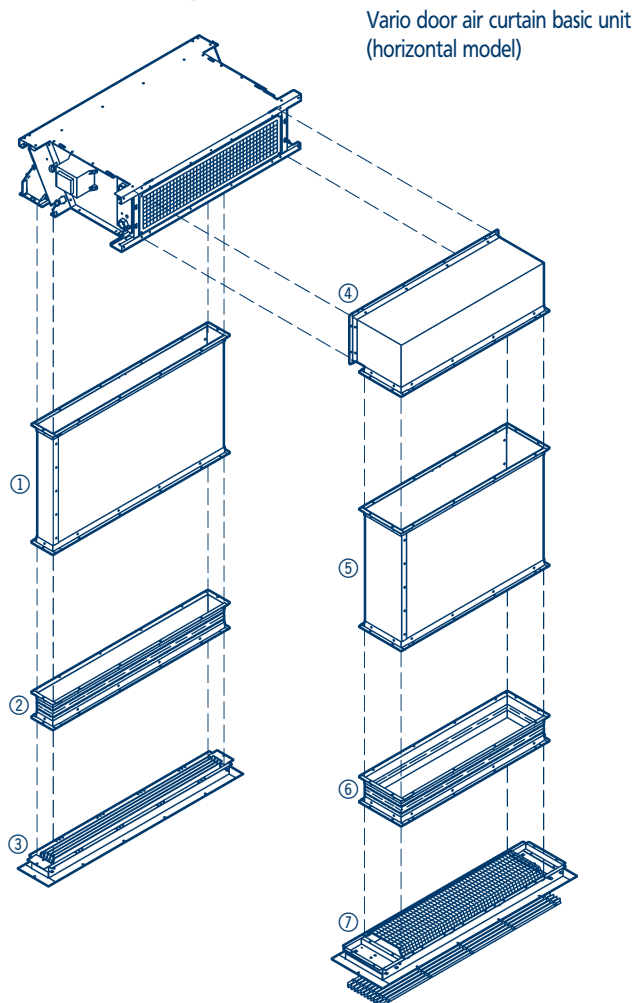

Vario door air curtain basic unit (horizontal model)

- ① Air duct for air outlet
- ② Flexible connection for air outlet
- ③ Leaving air rectifier
- ④ Inlet air angle 90°
- ⑤ Air duct for air inlet
- ⑥ Flexible connection for air inlet
- ⑦ Inlet air grille

For dimensions refer to page 22

Overview of sheet steel components				
Model size	10	15	20	25
① Air duct for air outlet	110881	115881	120881	125881
② Flexible connection for air outlet	110870	115870	120870	125870
③ Leaving air rectifier	110840	115840	120840	125840
④ Inlet air angle 90°	110850	115850	120850	125850
⑤ Air duct for air inlet	110880	115880	120880	125880
⑥ Flexible connection for air inlet	110860	115860	120860	125860
⑦ Inlet air grille	110830	115830	120830	125830
Replacement filter mat for inlet air grille	110820	115820	120820	125820

① Air duct for air outlet

with a frame on both sides; please state length when ordering

② Flexible connection for air outlet

with a frame on both sides and flexible connection made of sailcloth for sound attenuation and to even out the length when there are dimensional inequalities on site; installed length: 120-160 mm

③ Leaving air rectifier

Air rectifier for low-turbulence air flow, comprising an adjustable air flow-enhancing louvre set; reduced induction of outlet air with the discharged flat air stream inclined to produce lower divergence, whilst improving penetration depth; produces a marked reduction of the air exchange; completely powder-coated in traffic white RAL 9016; complete with steel metal frame; air rectifier sits within the frame

When installing door air curtains within suspended ceilings, a leaving air rectifier with a frame is used.

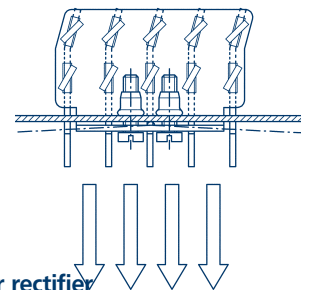

Cross-section through leaving air rectifier

④ Inlet air angle 90°

with connecting frame on both sides; short angle section for use as a transitional section between horizontal and vertical ductwork when door air curtains are installed within suspended ceilings;

⑤ Air duct for air inlet

with a frame on both sides; please state length when ordering.

⑥ Flexible connection for air inlet

with a frame on both sides and a flexible connection made of sailcloth for sound attenuation and to even out the length when there are dimensional inequalities: length: 120-160 mm

⑦ Inlet air grille

with a frame and filter fixing; the inlet grille, a linear grille made of airflow-enhancing aluminium droplet profiles, can be easily removed to remove the filter. The sheet steel frame and the grille are fully powdercoated in traffic white RAL 9016.

Replacement filter mat for inlet air grille

reusable dry layer filter G2 for fitting in the inlet air grille; 1 set = 5 mats

Fan control

The fans used in Kampmann Vario door air curtains can be switched between 5 fan speeds by means of integral transformers. When operated with 3-stage switches, any of the five switching stages can be selected. The summer/winter switches allow ventilation to be provided in summer, without hot water supply, using thermoelectric shut-off valves.

Vario door air curtains, with one fan group, can be operated with 3- or 5-stage switches.

Wiring

Please refer to page 11 for wiring details. Electrical ratings are given in the technical data pages 30 - 36. The measured values are the maximum values under poor conditions. The actual values can be even lower, depending on the location of the units, the accessories used and the level of dirt on the filter. Wiring should be done in accordance with German Electrical Association (VDE) and energy supply company directives.

Cascade module

Up to 10 door air curtains can be operated in parallel with one stage switch using a cascade module (see Table).

Number of cascade modules when operating door air curtains in parallel (maximum 10 units)

No. of Vario door air curtains	1	2	3	4	5	6	7	8	9	10
No. of cascade modules when stage switches are used	0	1	2	2	3	3	4	4	5	5

Remote radio controller, integral, type *_ _ _ _ _ -00W

All Kampmann door air curtains can be operated with a wireless, factory-fitted radio controller instead of with a stage switch.

- Transmitter accommodated within plastic housing RAL 9010, 80 x 80 x 15 mm
- Simple wall-mounting without the need for cabling
- 3-stage fan speed push-button control
- Summer/winter control is also possible
- Receiver unit fitted on unit
- Aerial included



Transmitter



Receiver aerial

Remote radio controller for door air curtains

Controls

*Insert door air curtain basic unit type number

Article no. for remote radio controller Datanorm/EDV
input: 151 000 _ _ _ _ _ -00W (Insert type no.)

Cabling

Operation of a single Vario door air curtain

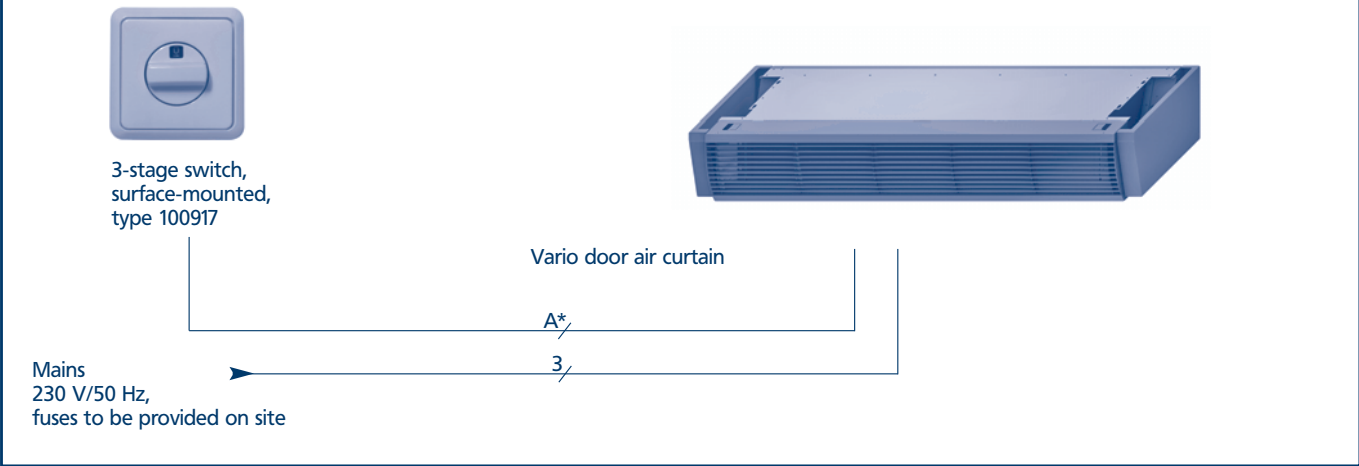

Parallel operation of Vario door air curtains

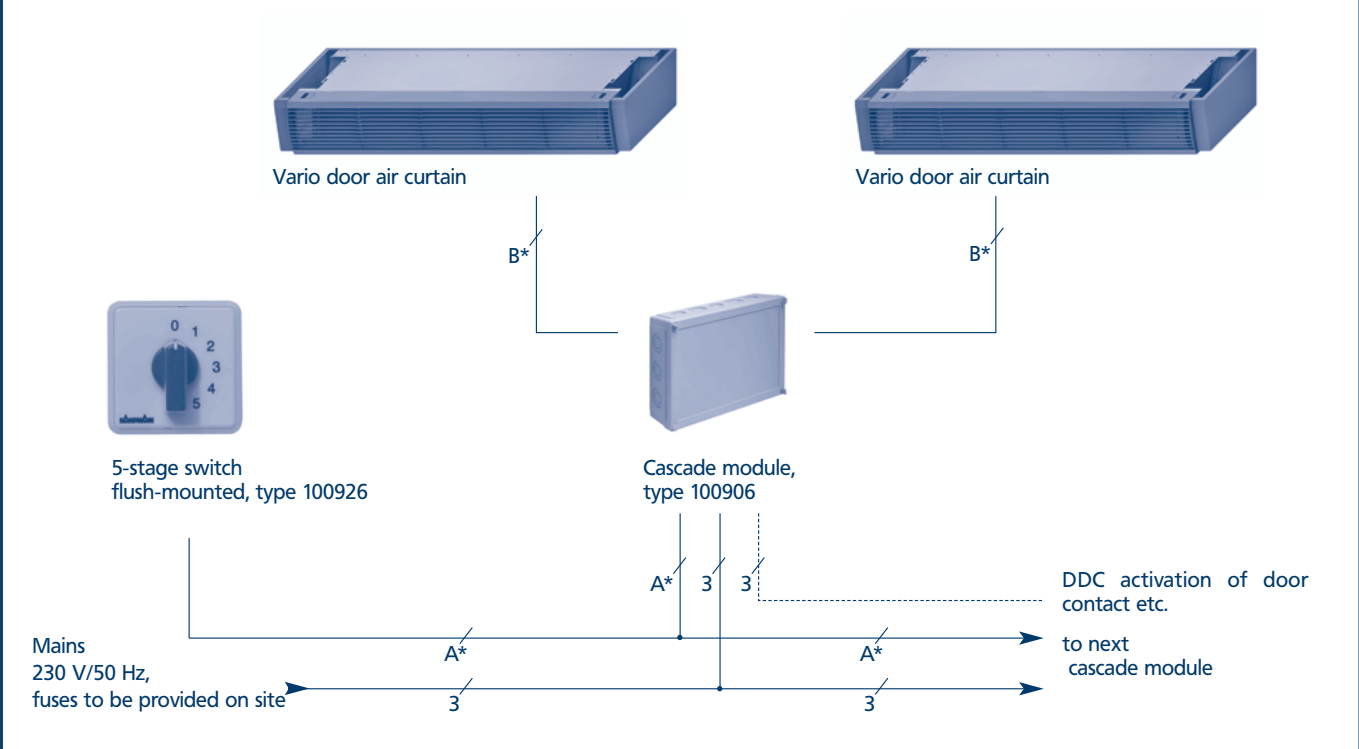

*See the table below for the number of wires for the cables designated with a letter. The number of wires for all other cables are given on the wiring diagram itself.

Number of wires including fuse

Cable	3-stage switch, type 100917/100918	3-stage summer/winter switch, type 100920/100922	5-stage summer/winter switch, type 100925/100926	5-stage summer/winter switch, type 100928/100929
A	5	6	8	8
B	6 (9)	7 (10)	9 (12)	9 (12)

The figure in brackets applies when a frost protection thermostat is used (only required when used in unheated rooms).

3- and 5-stage switches · Cascade modules



3-stage switch, surface-mounted, type 100917

3-stage switch 0-1-2-3, surface-mounted, type 100917

Housing	plastic, white, Jung
Switching capacity	10 A
Protection class	IP 21
Dimensions	H x W x D: 82 x 82 x 59 mm

3-stage switch 0-1-2-3, flush-mounted, type 100918

Assembly	in a 55 mm junction box
Cover	white, Jung
Switching capacity	10 A
Dimensions	H x W x D: 82 x 82 x 24* mm



3-stage summer/winter switch, flush-mounted type 100922

3-stage summer/winter switch 0-1-2-3, surface-mounted, type 100920

Housing	plastic, light/dark grey, insulated
Switching capacity	15 A
Protection class	IP 55
Dimensions	H x W x D: 82 x 82 x 125 mm

3-stage summer/winter switch 0-1-2-3, flush-mounted, type 100922

Assembly	in a 55 mm junction box
Cover	white
Switching capacity	15 A
Dimensions	H x W x D: 82 x 82 x 24* mm



5-stage switch, flush-mounted, type 100926

5-stage switch 0-1-2-3-4-5, surface-mounted, type 100925

Housing	plastic, light/dark grey, insulated
Switching capacity	15 A
Protection class	IP 55
Dimensions	H x W x D: 82 x 82 x 125 mm

5-stage switch 0-1-2-3-4-5, flush-mounted, type 100926

Assembly	in a 55 mm junction box
Cover	white
Switching capacity	15 A
Dimensions	H x W x D: 82 x 82 x 24* mm



5-stage summer/winter switch, surface-mounted, type 100928

5-stage summer/winter switch 0-1-2-3-4-5, surface-mounted, type 100928

Housing	plastic, light/dark grey, insulated
Switching capacity	15 A
Protection class	IP 55
Dimensions	H x W x D: 82 x 82 x 125 mm

5-stage summer/winter switch 0-1-2-3-4-5, flush-mounted, type 100929

Assembly	in a 55 mm junction box
Cover	white
Switching capacity	15 A
Dimensions	H x W x D: 82 x 82 x 24* mm



Cascade module, surface-mounted, type 100906

Housing	plastic, light grey
Protection class	IP 65
Dimensions	H x W x D: 179 x 255 x 72 mm

Controls

Article no. for DataNorm/EDV entry
Controls accessories: 196 000 (Insert type)

Control valves

Outlet temperatures that are too high reduce the penetration depth of the door air curtain air stream. The outlet temperature should also not exceed 40 °C for energy-saving reasons. The use of a leaving air temperature limiting valve means that it is possible to maintain the controller at a constant value. In summer mode, an additional thermoelectric shut-off valve is used to prevent the air stream heating up.

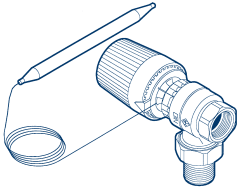
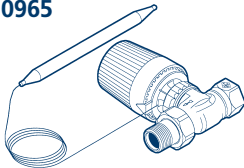
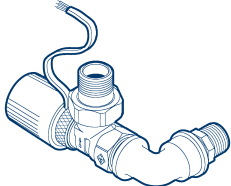
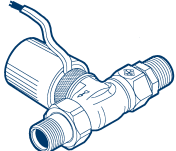
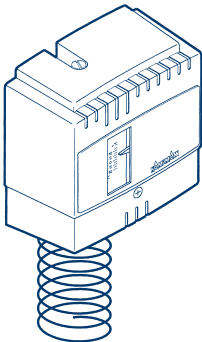
Control valves • Frost protection thermostat																	
 <p>Leaving air temperature limiting valve, type 100965</p>  <p>Leaving air temperature limiting valve, type 100966</p>	<p>Leaving air limiting valve</p> <p>Available as a straight or angled valve body with a thermostatic head and remote sensor with a 2 m capillary tube to control the leaving air temperature at a constant value; the valve comes complete with fixings for mounting the sensor in the air stream; temperature setting range 20-50 °C</p> <table border="1"> <thead> <tr> <th>Model</th> <th>Vario door air curtain</th> </tr> </thead> <tbody> <tr> <td>horizontal</td> <td>Type 100965, 3/4", angled</td> </tr> <tr> <td>vertical</td> <td>Type 100960, 3/4", straight</td> </tr> <tr> <td>standing</td> <td>Type 100966, 1", straight</td> </tr> </tbody> </table>	Model	Vario door air curtain	horizontal	Type 100965, 3/4", angled	vertical	Type 100960, 3/4", straight	standing	Type 100966, 1", straight								
Model	Vario door air curtain																
horizontal	Type 100965, 3/4", angled																
vertical	Type 100960, 3/4", straight																
standing	Type 100966, 1", straight																
 <p>Thermoelectric shut-off valve, type 100910</p>  <p>Thermoelectric shut-off valve, type 100911</p>	<p>Thermoelectric shut-off valve</p> <p>Available as an angled or straight valve body with a thermoelectric actuator 230 V, 50 Hz (closed in a de-energised state); for use with 3- and 5-stage summer/winter switches (type 100920, type 100922, type 100928, type 100929) or 5-stage controller type 200925, to close off the heating circuit in summer</p> <table border="1"> <thead> <tr> <th>Model</th> <th>Vario door air curtain</th> </tr> </thead> <tbody> <tr> <td>horizontal</td> <td>Type 100910, 3/4", angled</td> </tr> <tr> <td>vertical</td> <td>Type 100900, 3/4", straight</td> </tr> <tr> <td>standing</td> <td>Type 100911, 1", straight</td> </tr> </tbody> </table>	Model	Vario door air curtain	horizontal	Type 100910, 3/4", angled	vertical	Type 100900, 3/4", straight	standing	Type 100911, 1", straight								
Model	Vario door air curtain																
horizontal	Type 100910, 3/4", angled																
vertical	Type 100900, 3/4", straight																
standing	Type 100911, 1", straight																
 <p>Frost protection thermostat, type 030268</p>	<p>Frost protection thermostat, loose, type 030268, fitted type * _ _ _ _ _ -F</p> <p>Only required when door air curtains are fitted in unheated rooms (porches or vestibules) where a thermoelectric shut-off valve is used; the unit is fitted to the leaving air side of the heat exchanger and set to approximately +8 to +10 °C (minimum +5 °C); should the temperature fall below this pre-set value, the fan is switched off and the thermoelectric shut-off valve is opened. Once the temperature rises above the pre-set value, the fan starts up again automatically; with integral filter monitoring, 3 m capillary tube, setting range -10/+12 °C, switching capacity 8 A</p> <table border="1"> <tbody> <tr> <td>Housing</td> <td>galvanised sheet steel</td> </tr> <tr> <td>Sensor</td> <td>copper, gas-filled</td> </tr> <tr> <td>Protection class</td> <td>IP 40</td> </tr> <tr> <td>Protection class</td> <td>I</td> </tr> <tr> <td>Contact</td> <td>potential-free changeover contact 24-250 V AC/15(8) A</td> </tr> <tr> <td>Setting range</td> <td>-10 to +12 °C</td> </tr> <tr> <td>Switching differential</td> <td>1 kelvin</td> </tr> <tr> <td>Dimensions</td> <td>W x H x D: 105 x 112 x 55 mm</td> </tr> </tbody> </table>	Housing	galvanised sheet steel	Sensor	copper, gas-filled	Protection class	IP 40	Protection class	I	Contact	potential-free changeover contact 24-250 V AC/15(8) A	Setting range	-10 to +12 °C	Switching differential	1 kelvin	Dimensions	W x H x D: 105 x 112 x 55 mm
Housing	galvanised sheet steel																
Sensor	copper, gas-filled																
Protection class	IP 40																
Protection class	I																
Contact	potential-free changeover contact 24-250 V AC/15(8) A																
Setting range	-10 to +12 °C																
Switching differential	1 kelvin																
Dimensions	W x H x D: 105 x 112 x 55 mm																

Controls

*Insert door air curtain basic unit type

Article no. for DataNorm/EDV entry
 Frost protection thermostat, fitted: 151 000 (Insert type)

Controls

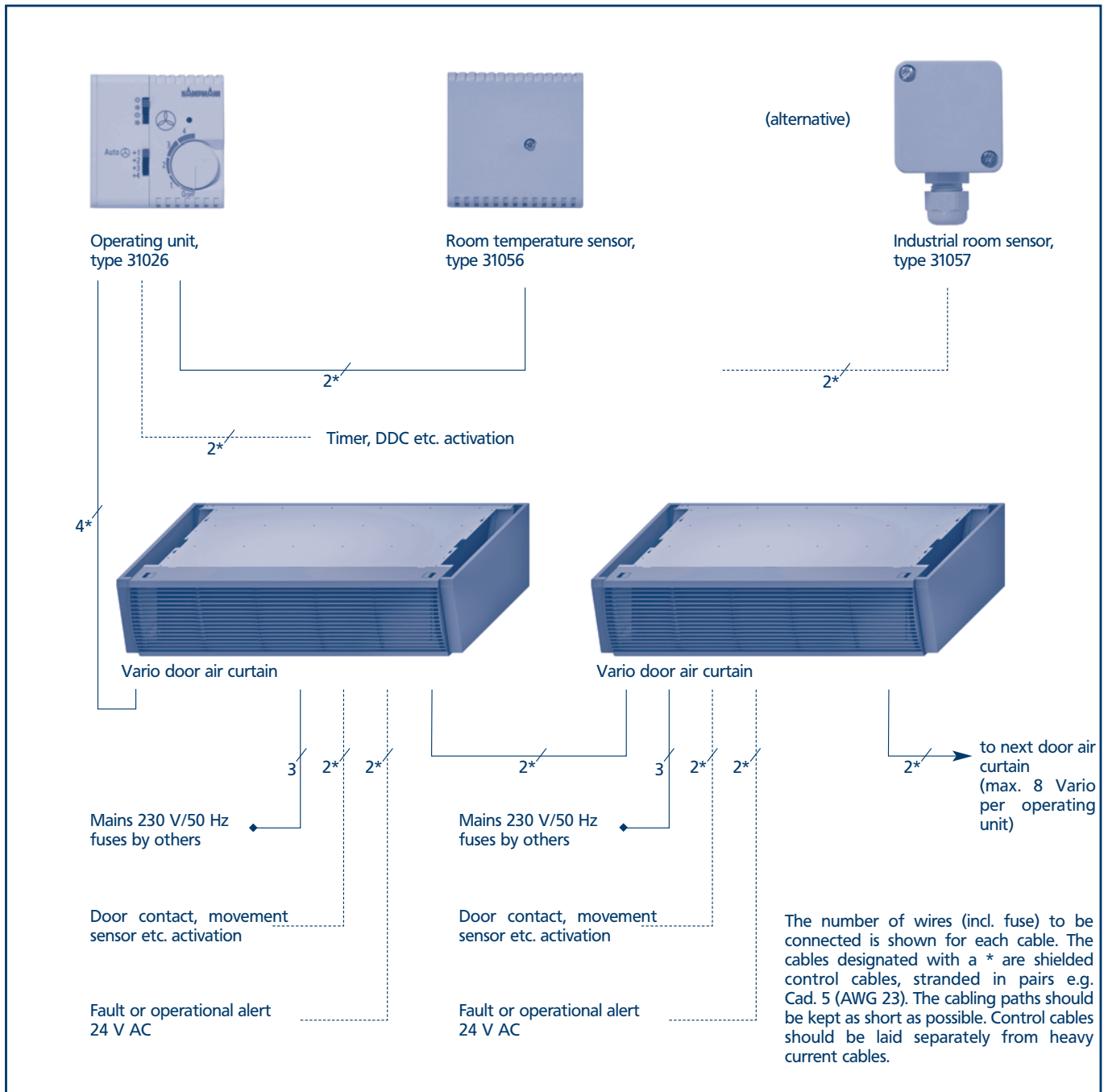

BUS Controller with the KaBUS ECO system

The KaBUS ECO control system has been designed as a multi-functional control system for door air curtains. Up to eight units can be controlled via a BUS cable using the operating unit. All the electronics are concealed on the door air curtains themselves. The system can be configured for summer and/or winter mode. In addition to controlling the waterside valves, it is also possible to set a 4-stage fan mode, optionally with demand-led fan speed increase.

Room temperature controller and fan run-on function are included. The operating unit, with integral room temperature sensor, is very user-friendly. It is possible to control it from external timers, movement alarms or DDC equipment

Article no. for DataNorm/EDV entry
Controls accessories 196 000 (Insert type)

BUS controller with the KaBUS ECO system

BUS controller with the KaBUS ECO system



KaBUS ECO operating unit type 031026

KaBUS ECO operating unit, type 031026

The KaBUS ECO operating unit serves to control the system, including fan stage, fan speed increase, room temperature set values, fan run-on time, summer/winter mode. An integral operating LED displays the operating mode.

Housing	white, surface-mounted on a 55 mm back box
Room temperature set point	5 - 25 °C
Switching differential	+/- 0.8 K
Fan run-on time - without room temperature controller - with room temperature controller	0 - 10 min adjustable 2 min fixed
Digital input	external activation i.e. timer
Protection class	IP 30
Protection class	III (safety low voltage)
Dimensions	W x H x D: 70 x 70 x 26 mm



KaBUS ECO power module type ___*___-00B

KaBUS ECO Power module, fitted, type ___*___-00B

The KaBUS ECO power module is factory-fitted on the door air curtain and serves to control the valve and the fan group that can be switched between 4 stages. The different operating programmes are selected by the DIP switched integrated within the power module. Not suitable for use with door air curtains with remote radio control.

Housing	steel
Voltage	230 V AC/50 Hz
Fan switching output	230 V AC/50 Hz 10 A inductive
Valve switching output	230 V AC/50 Hz 3 A inductive
Operation/fault switching output	24 V DC/30 mA
Digital input	frost alert
Digital input	door contact/movement alert etc.
Protection class	IP 20
Dimensions	W x H x D: 207 x 185 x 75 mm



Room temperature sensor type 031056

Room temperature sensor type 031056

The separate room temperature sensor type 031056 is required if the room temperature sensor integrated within the operating unit cannot be used for any reason, possibly because of a poor fixing location.

Housing	white, surface-mounted in a 55 mm back box
Measuring range	0 to 51 °C
Protection class	IP 20
Protection class	III (safety low voltage)
Dimensions	W x H x D: 70 x 70 x 26 mm



Industrial room sensor, type 031057

Industrial room sensor type 031057

For use in areas where there is a high concentration of dust or high levels of humidity.

Housing	surface-mounted on the wall
Measuring range	0 to 51 °C
Protection class	IP 54
Protection class	III (safety low voltage)
Dimensions	B x H x T: 70 x 70 x 26 mm

Thermoelectric shut-off valve and frost protection thermostat see p 13; also available

Frost prot. thermostat and KaBUS ECO power module, fitted, type ___*___-F0B

Frost prot. thermostat and remote radio controller, fitted type ___*___-F0W

Controls

*Insert door air curtain basic unit type

Article no. for DataNorm/EDV entry 196 000 (Insert type)
KaBUS ECO power module: 151 000 (Insert type) ___-00B

Evaluation criteria	Pressure conditions/requirements/environment	Points
Wind pressure conditions		<input type="checkbox"/> points
Passage/Porch		<input type="checkbox"/> points
Position of the building		<input type="checkbox"/> points
Area constantly used by people		<input type="checkbox"/> points
Pressure conditions due to mechanical ventilation		<input type="checkbox"/> points
Other thoroughfares/doorways		<input type="checkbox"/> points
Room height		<input type="checkbox"/> points
Floor area		<input type="checkbox"/> points
Distance from air outlet to doorway		<input type="checkbox"/> points
*Intermediate figures are possible		<input type="checkbox"/> points
Points total		<input type="checkbox"/> points

Design information

Selection process

Points should be allocated according to the circumstances on site, in terms of the different influencing factors/evaluation criteria as per the above scale.

- Intermediate figures are possible.
- Extreme cases for certain influencing factors beyond the scale can also be taken into account. The sum of the points in the right-hand column gives the points total for determining the maximum discharge heights and widths according to the switching stages given on Diagram 1.
- The limit values (see p 19) should be observed with doors that are constantly open
- H_{max} : Maximum discharge height for Vario horizontal and vertical
- W_{max} : Maximum discharge width for Vario standing, single side

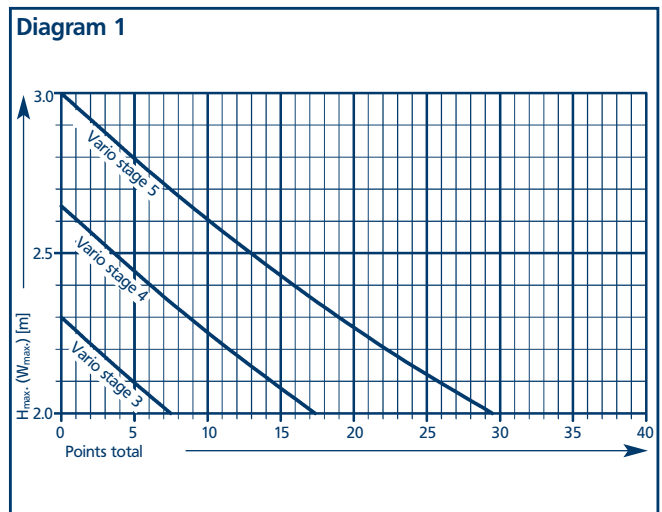

Evaluation criteria	Pressure conditions/requirements/environment	Points
Wind pressure conditions		1 points
Passage/Porch		0 points
Position of the building		0 points
Area constantly used by people		1 points
Pressure conditions due to mechanical ventilation		1 points
Other thoroughfares/doorways		2 points
Room height		2 points
Floor area		1 points
Distance from air outlet to doorway		1 points
*Intermediate figures are possible		Points total
		9 points

Design information

Selection example:

Given:

- Door air curtain for sales room, door height 2.20 m, width 2.00 m
- Slight air flow (wind)
- Porch or passage - present
- Normal, protected position
- Sales staff in zone II
- Slight excess pressure in the room
- Side thoroughfare
- Room height 3.50 m
- Floor area 200 m²
- Distance from air outlet to doorway 100 mm

Selection:

- Door air curtain model 20, so that unit length = door width
- Evaluation see table: points total 9
- Discharge height = Door height + a
= 2.2 m + 0.1 m = 2.3 m
- From diagram 1: Minimum requirements with 9 points: Vario door air curtain, fan stage 4 with H_{max.} = 2.30 m
- Result: Vario door air curtain, model 20

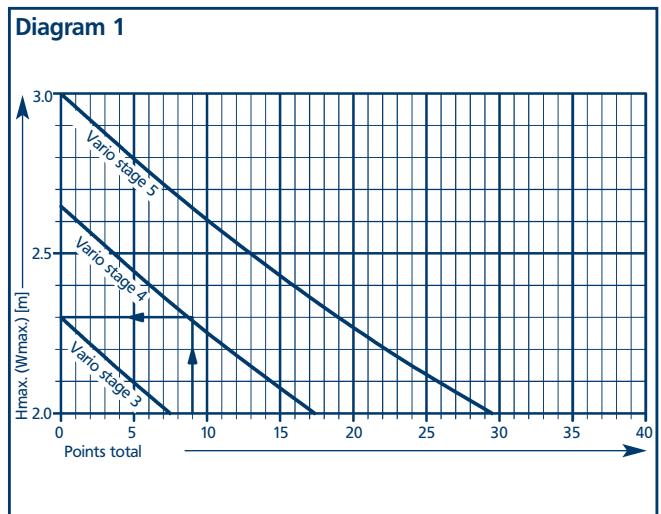

Unit selection

The following should be considered when selecting a unit:

- Door width/height (standing model)
- Max. discharge height H
- Max. discharge width (standing model)

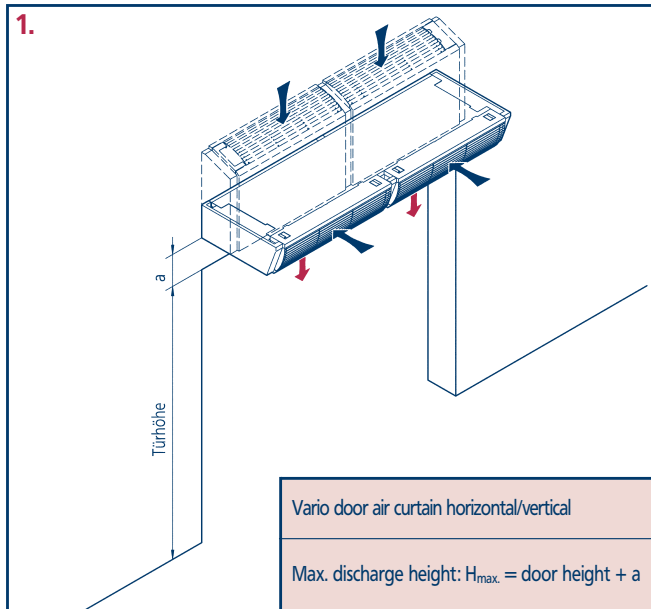

1. Calculation based on the max. discharge height

- Max. discharge height $H = \text{Door height} + a$

The following should also be taken into consideration:

- Fan stage
- Wind pressure conditions
- Influence of passages/porch/position of the building
- Areas used by people
- Pressure conditions due to mechanical ventilation etc.

Selection based on max. discharge height H^1 : 2.3 - 3.0 m

2. Calculation based on discharge width and door height (Vario, standing unit)

see Diag. 2.

3. Calculation based on door width

Selecting the required unit based on the door width:

- Door width = Unit length B

The lengths of the units are based on common door dimensions. Other lengths can be achieved by combining basic units of the same or different sizes or with the use of appropriate casing extensions (see table below).

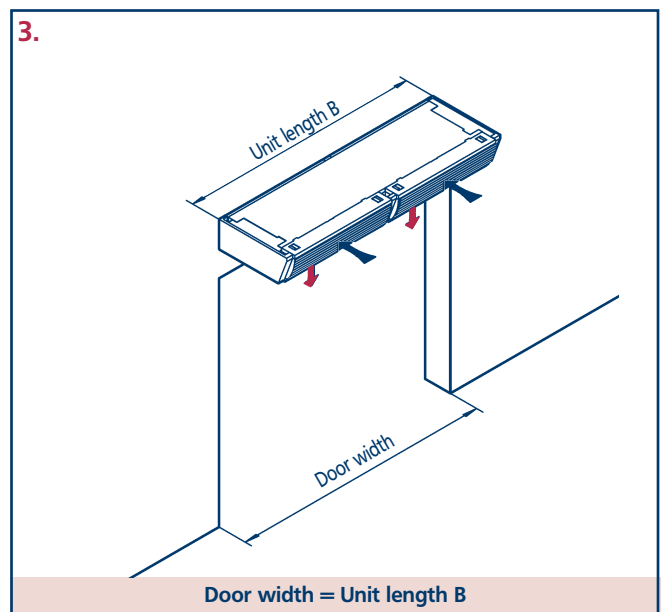
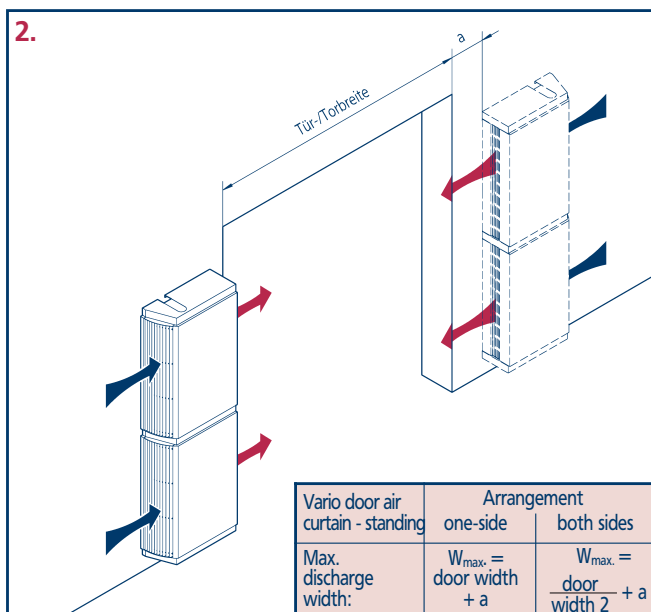

Combination options

Door width							
1.0 m	1.5 m	2.0 m	2.5 m	3.0 m	3.5 m	4.0 m	4.5 m
Model 10	Model 15	Model 20	Model 25	2 x Model 15	Model 20 + Model 15 Model 25 + Model 10	2 x Model 20	Model 20 + Model 25

¹With average to good pressure conditions/requirements/environment

²Shown up to door width 4.5 m, other widths are possible by combining units

Arrangement

When door air curtains are arranged above the door (horizontal and vertical models), the units must be mounted in such a way that the outlet air grille sits as closely as possible to the door opening, and preferably directly adjacent to it. When arranged beside the doorway (standing models), it must also be ensured that the outlet air grille is positioned as closely as possible to the door opening.

Where there is a horizontal or vertical gap of more than around 500 mm between the door opening and the outlet grille, the next unit length up should be selected or side panels, not dissimilar to a corridor, have to be fitted.

Limits of use

Extremely poor operating conditions, such as

- serious low pressure in the room, caused by mechanical ventilation without the supply of external air,
- extremely poor weather conditions, with high wind speeds in an unsheltered position,
- several open thoroughfares outside, particularly if they are located opposite each other,

can impair the effective screening effect of the door air curtains. Additional measures may be required to compensate for this. It should be taken into consideration when designing thoroughfares, that it may be necessary to close the doors even during business hours.

With standing door air curtains, the use of units on both sides of the door may be required with poor installation conditions.

Should doors, say in large department stores, have to be open, even in poor or extreme weather conditions, then units with a significantly higher air volume and heat output should be used. They must be capable of heating up the larger volumes of cold air.

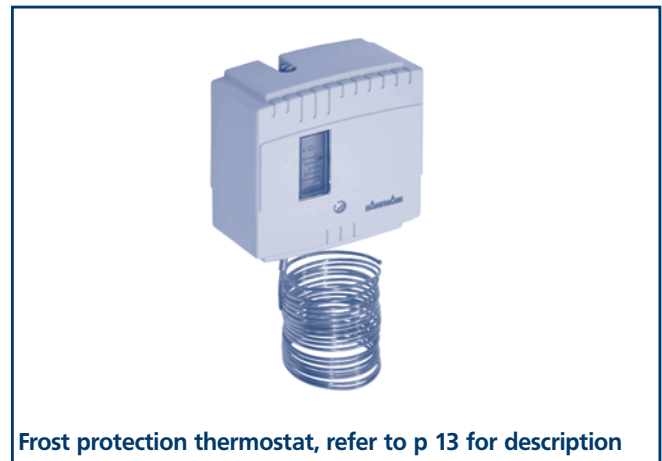

Frost protection thermostat, refer to p 13 for description

Frost protection

If door air curtains are used in unheated rooms, such as porches, a frost protection thermostat is required to prevent the heat exchanger from freezing. This switches the fans off if there is a risk of frost, and opens the thermoelectric shut-off valve, should one be used (see p 13).

The frost protection thermostat is factory-fitted on the door air curtain, if the suffix -F is added to the end of the door air curtain type no.; it can also be supplied separately.

Low temperature operation

Modern low temperature and condensing boilers work most efficiently with low flow temperatures. Kampmann Vario door air curtains have high-output copper/aluminium heat exchangers and are ideal for use in low temperature mode with a flow temperature of approx. 50 °C. The very low water content and fan operation with high air flows mean that they react very quickly to longer cool-down times.

Sound pressure level

The aerodynamic construction of the Vario door air curtain has a very low noise level in spite of high outlet air velocity. It should nevertheless be borne in mind that the noise level can be rather annoying at higher fan speeds. The sound pressure levels are given in the technical data tables.

The sound pressure levels quoted have been calculated in an anechoic room with medium absorption at a distance of 3 m from the air inlet. As the actual sound pressure level is seriously dependent on the acoustic properties of the room, the given values can vary in practice. There can be increase in sound pressure level of up to 3-6 dB (A) with acoustically poor conditions, such as reverberant ceilings, closed doorways and poor absorption surfaces. If two door air curtains of the same model are arranged side by side, the sound pressure level increases by approximately 2-3 dB (A).

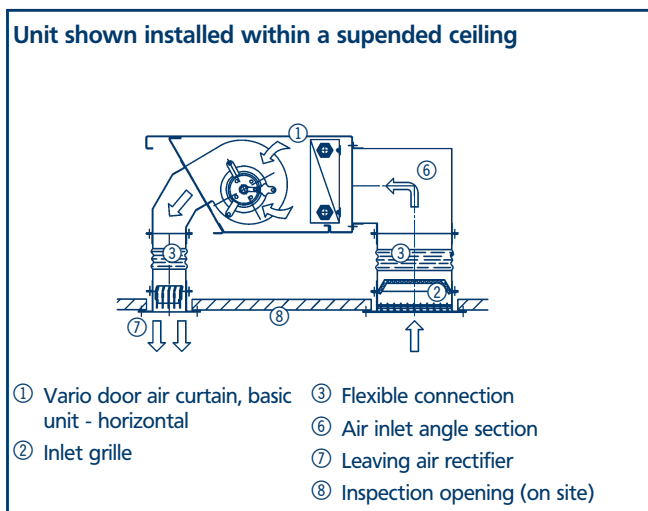

Conversion to other flow and return temperatures

Conversion to other flow and return temperatures

Heat outputs for different water temperatures can be found in the technical data tables on pages 30 to 35.

The following formulae and heat output correction factors from Diagram 2 can be used to calculate the heat output with water temperatures which are not listed in the tables.

Key

- t_{w1} [°C] = Flow temperature
- t_{w2} [°C] = Return temperature
- Δt [K] = Average excess temperature
- Δt_w [K] = Water temperature difference
- t_{L1} [°C] = Entering air temperature
- Q [W] = Heat output
- Q_n [W] = Nominal heat output at LPHW 75/65 °C, $t_{L1} = 20$ °C
- f [] = Heat output correction factor
- \dot{m} [l/h] = Water flow rate
- R [kPa] = Water pressure
- V [m³/h] = Air volume
- C [Wh/m³K] = Multiplier for outlet air temp. calculation = 0.34 wh/m³K

Calculation formulae

$\Delta t = \frac{t_{w1} + t_{w2}}{2} - t_{L1} \quad (1)$	$Q = Q_n \cdot f \quad (3)$
$\Delta t_w = t_{w1} - t_{w2} \quad (2)$	$\dot{m} = \frac{Q}{\Delta t_w} \cdot 0,86 \quad (4)$
$t_{L2} = t_{L1} + \frac{Q}{V \cdot c} \quad (5)$	

Calculation example

given: Vario door air curtain, model 15 horizontal, type 115330
 Flow temperature $t_{w1} = 65$ °C
 Return temperature $t_{w2} = 55$ °C
 Leaving air temperature $t_{L1} = 18$ °C

required: Heat output Q at fan stage 5
 Leaving air temperature t_{L2}
 Water pressure R

Calculation

$$\Delta t = \frac{t_{w1} + t_{w2}}{2} - t_{L1} \quad (1) \quad \Delta t = \frac{65 + 55}{2} - 18 = \underline{42 \text{ K}}$$

$$\Delta t_w = t_{w1} - t_{w2} \quad (2) \quad \Delta t_w = 65 - 55 = \underline{10 \text{ K}}$$

from diagram 2: $f = 0.81$

from table on p 31: $Q_n = 17360 \text{ W}$
 (LPHW 75/65 °C, $t_{L1} = 20$ °C)

$$V = 2130 \text{ m}^3/\text{h}$$

$$Q = Q_n \cdot f \quad (3) \quad Q = 17360 \text{ W} \cdot 0.81 = \underline{\underline{14062 \text{ W}}}$$

$$\dot{m} = \frac{Q}{\Delta t_w} \cdot 0,86 \quad (4) \quad \dot{m} = \frac{14062}{10} \cdot 0.86 = 1209 \text{ l/h}$$

from diagram 3, p 21, Vario door air curtain, model 15

from diagram on p 17: $R = \underline{\underline{6.7 \text{ kPa}}}$

$$t_{L2} = t_{L1} + \frac{Q}{V \cdot c} \quad (5) \quad t_{L2} = 18 + \frac{14062}{2130 \cdot 0.34} = \underline{\underline{37.4 \text{ °C}}}$$

Result

Heat output $Q = 14062 \text{ W}$
 Leaving air temperature $t_{L2} = 37.4$ °C
 Water pressure $R = 6.7 \text{ kPa}$

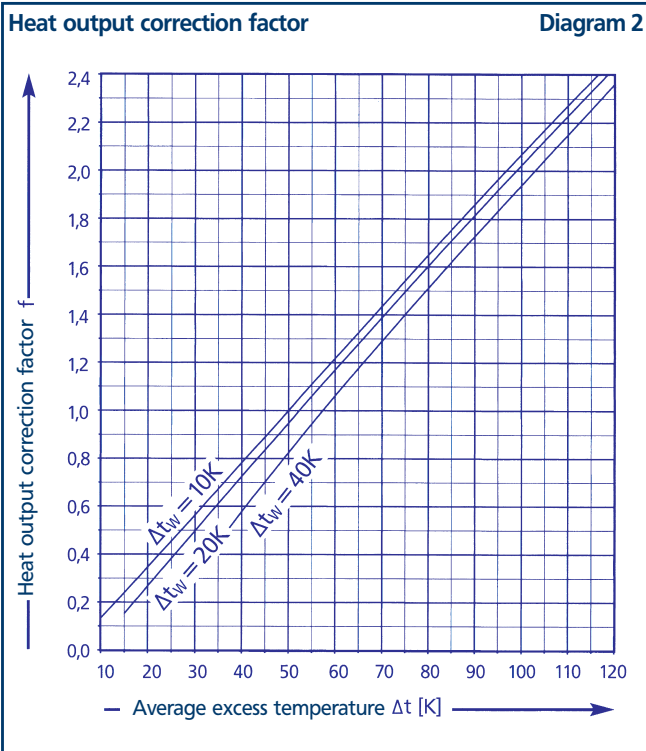

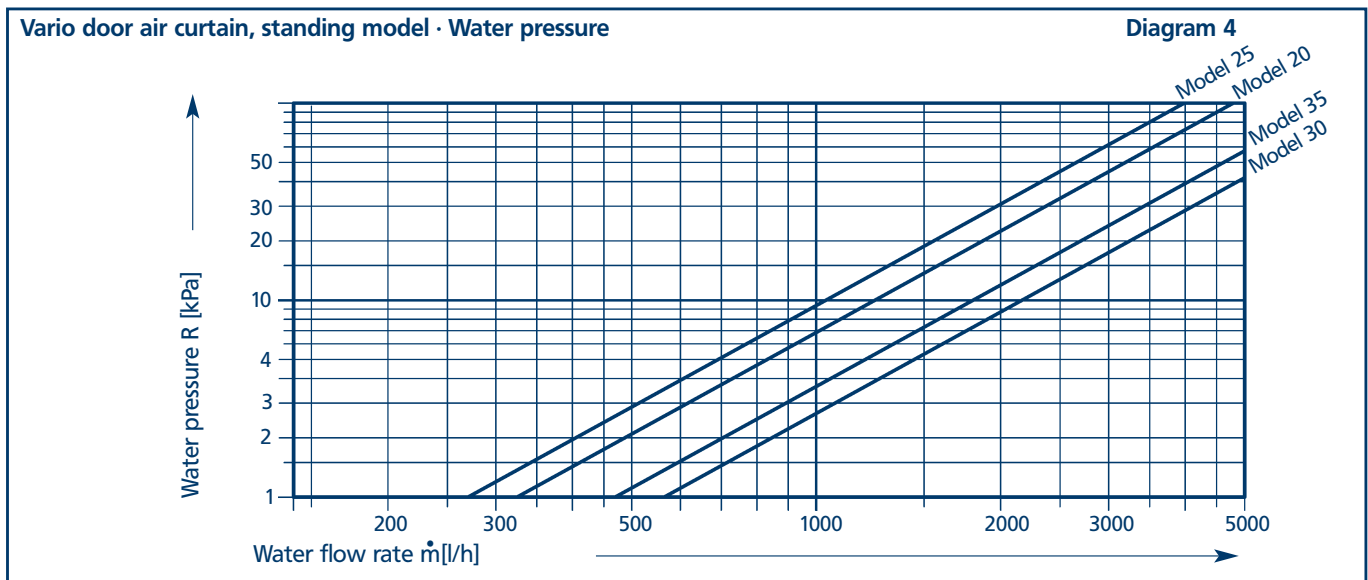
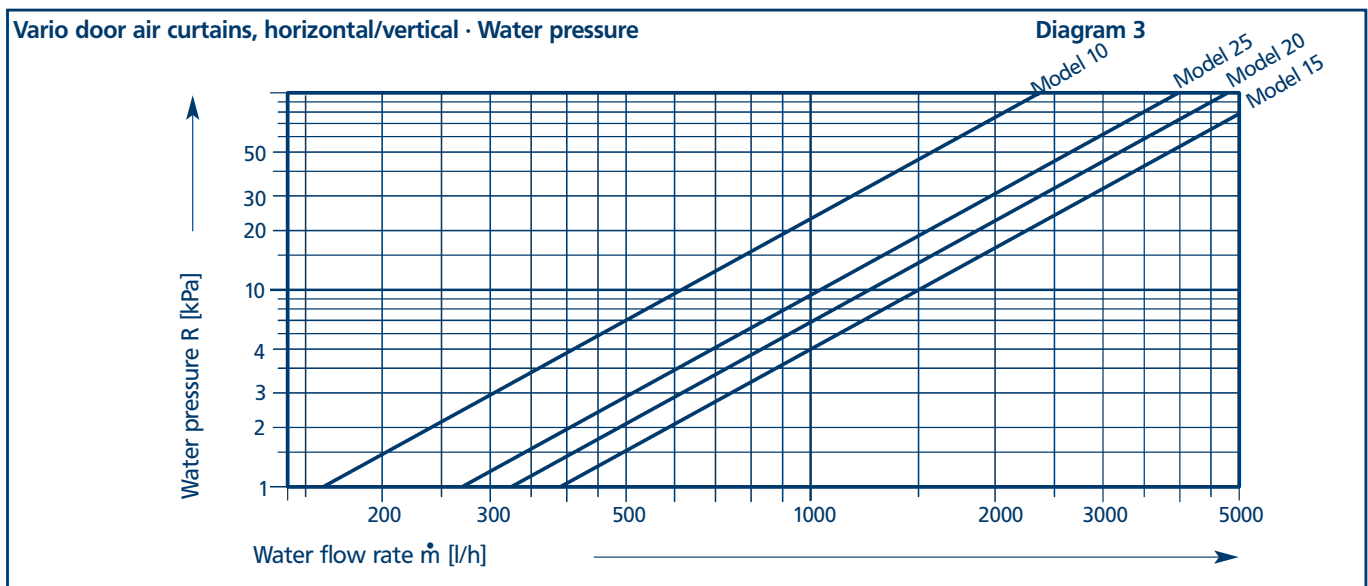

Water pressure

The water pressure can be calculated from Diagram 3 for the respective horizontal and vertical door air curtain sizes and from Diagram 4 for standing unit sizes.

The flow rate can be calculated using the formulae on p 20. The pressure diagrams apply for LPHW with an average water temperature of 70 °C.

There must be hydraulic balancing when used together with conventional heating units.

Dimensions of sheet steel components

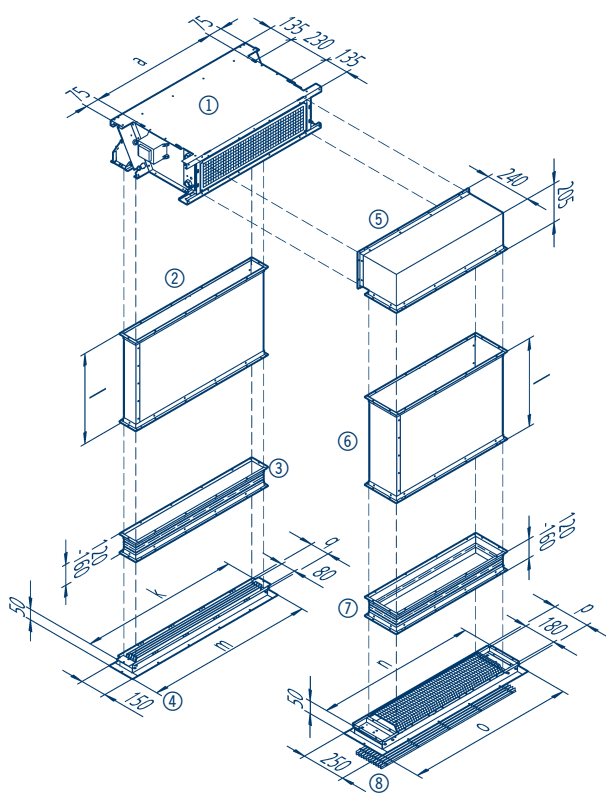

- ① Vario door air curtain, basic unit, horizontal model
- ② Air duct for air outlet
- ③ Flexible connection for air outlet
- ④ Leaving air rectifier
- ⑤ Inlet air angle section 90°
- ⑥ Air duct for air inlet
- ⑦ Flexible connection for air inlet
- ⑧ Inlet air grille

Air outlet

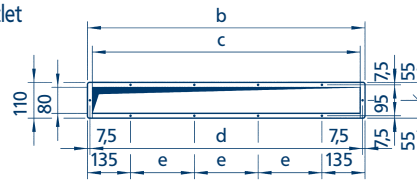

Air inlet

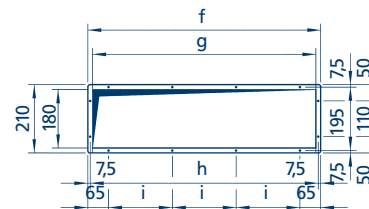

Overall dimensions

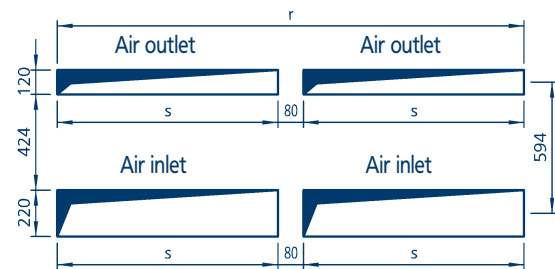

Opening dimensions

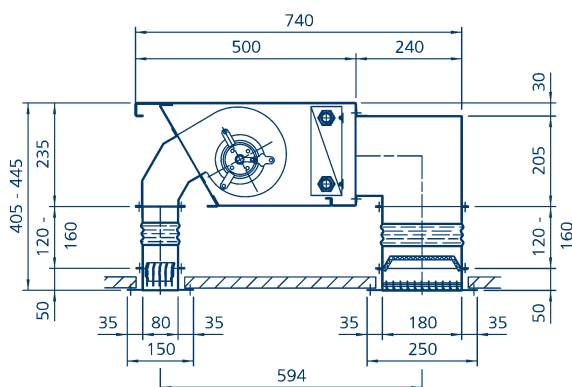

Installation within a suspended ceiling

Horizontal model

Model	10	15	20	25
a	730	1230	1730	2230
b	870	1370	900*	1150*
c	840	1340	870*	1120*
d	855	1355	885*	1135*
e	200	220	200	212,5
f	730	1230	820*	1070*
g	700	1200	790*	1040*
h	715	1215	805*	1055*
i	200	220	200	212,5
k	884	1384	884*	1134*
l	Please state dimension with order			
m	954	1454	954*	1204*
n	884	1384	884*	1134*
o	954	1454	954*	1204*
p	210	210	210	210
q	110	110	110	110
r	-	-	1920	2420
s	920	1420	920*	1170*

*Two sets of sheet steel components are supplied for door air curtain models 20 and 25. All dimensions are given in mm

Dimensions of models 10 and 15, horizontal

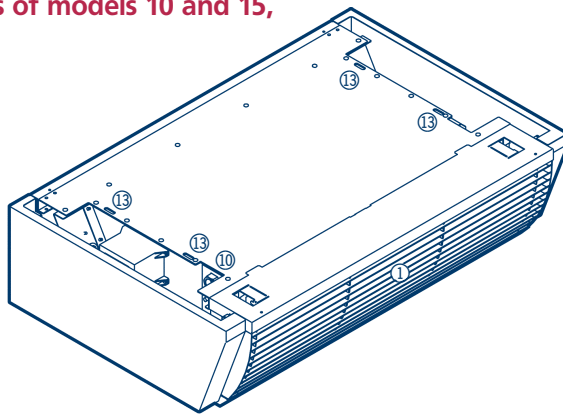

Horizontal door air curtain with basic unit casing

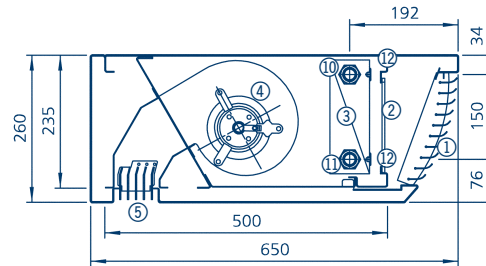

Cross-section through basic unit with casing

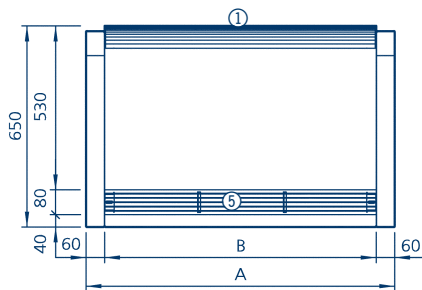

Basic unit casing, view from below

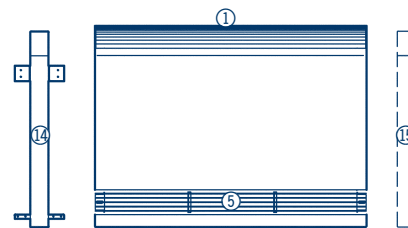

Casing extension

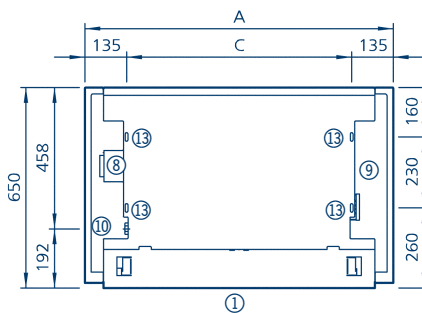

Basic unit with casing, top view

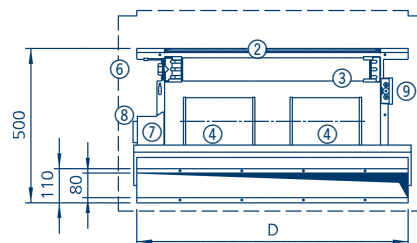

Basic unit without casing, view from below
Model 10 is shown

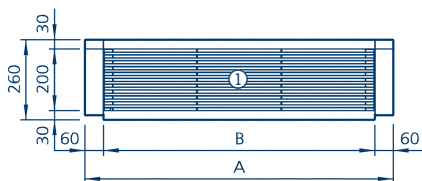

Basic unit casing, view of air inlet

- ① Inlet air grille
- ② Filter G2
- ③ Heat exchanger (copper/aluminium)
- ④ Radial fan
- ⑤ Leaving air rectifier
- ⑥ Casing outline
- ⑦ Electrical terminal box for thermoelectric shut-off valve
- ⑧ Transformer
- ⑨ Electrical connection
- ⑩ Flow connection 3/4"
- ⑪ Return connection 3/4"
- ⑫ Air vent and drain cock
- ⑬ Fixing holes
- ⑭ Connecting angle section for casing extension
- ⑮ Outline of basic unit casing end panel

Model	10	15
A	1000	1500
B	880	1380
C	730	1230
D	880	1380

All dimensions are given in mm

Technical data

Dimensions of models 20 and 25, horizontal

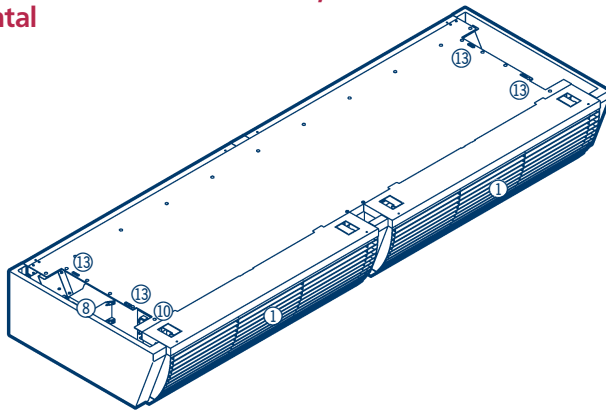

Door air curtain, horizontal with basic unit casing

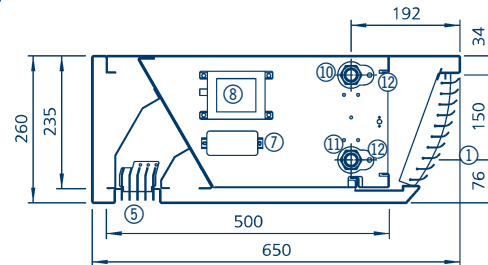

Side view of basic unit with casing

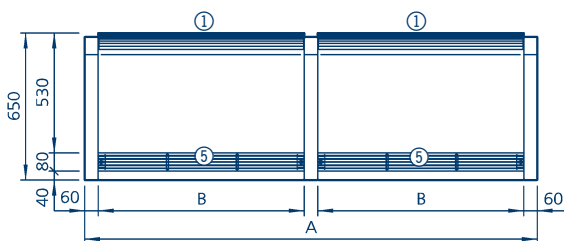

Basic unit casing, view from below

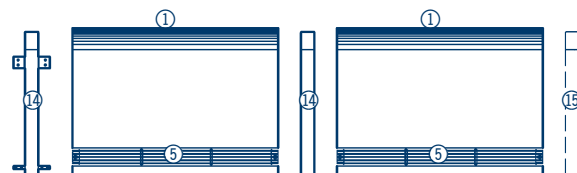

Casing extension

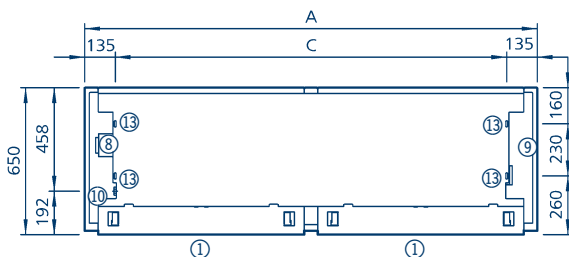

Basic unit with casing - top view

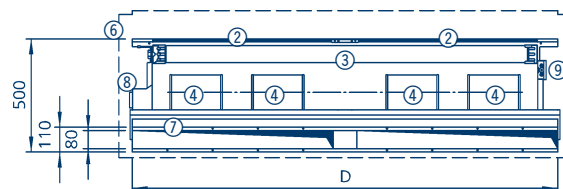

Basic unit without casing, view from below
Model 20 shown

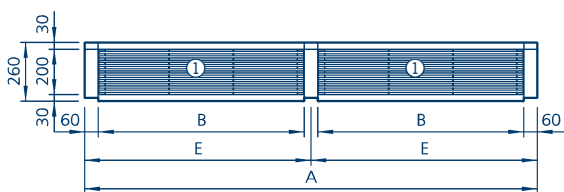

Basic unit casing, view of air inlet

- ① Inlet air grille
- ② Filter G2
- ③ Heat exchanger (copper/aluminium)
- ④ Radial fan
- ⑤ Leaving air rectifier
- ⑥ Casing outline
- ⑦ Electrical terminal box for thermoelectric shut-off valve
- ⑧ Transformer
- ⑨ Electrical connection
- ⑩ Flow connection 3/4"
- ⑪ Return connection 3/4"
- ⑫ Air vent and drain cock
- ⑬ Fixing holes
- ⑭ Connecting angle section for casing extension
- ⑮ Outline of basic unit casing end panel

Model	20	25
A	2000	2500
B	910	1160
C	1730	2230
D	1880	2380
E	1000	1250

All dimensions are given in mm

Dimensions of models 10 and 15, vertical

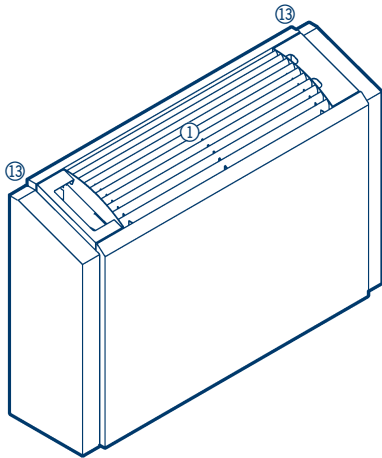

Vertical door air curtain with basic unit casing

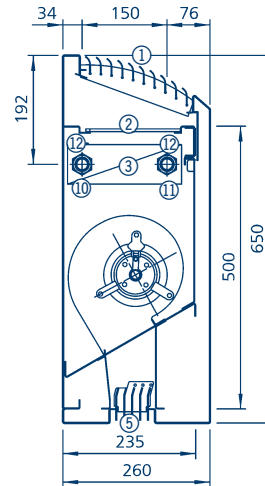

Cross-section through basic unit with casing

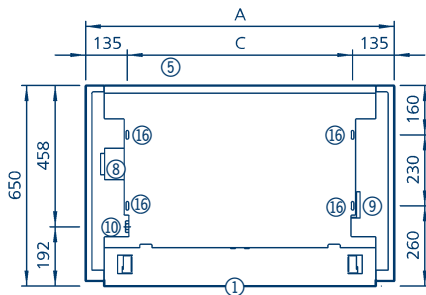

Basic unit casing, view from behind

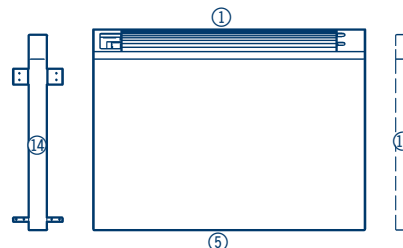

Casing extension

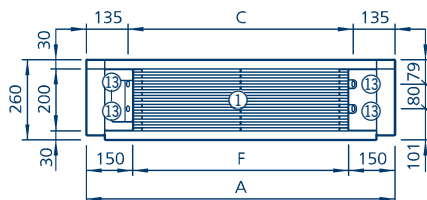

Basic unit with casing, top view

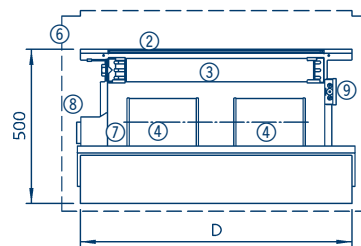

Basic unit without casing, front view
Model 10 shown

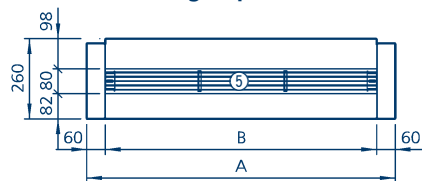

Basic unit casing, view of air outlet

- ① Inlet air grille
- ② Filter G2
- ③ Heat exchanger (copper/aluminium)
- ④ Radial fan
- ⑤ Leaving air rectifier
- ⑥ Casing outline
- ⑦ Electrical terminal box for thermoelectric shut-off valve
- ⑧ Transformer
- ⑨ Electrical connection
- ⑩ Flow connection 3/4"
- ⑪ Return connection 3/4"
- ⑫ Air vent
- ⑬ Fixing holes for fitting with wall or ceiling brackets
- ⑭ Connecting angle for casing extension
- ⑮ Outline of basic unit casing end panel
- ⑯ Fixing holes for fixing directly onto the wall

Model	10	15
A	1000	1500
B	880	1380
C	730	1230
D	880	1380
F	730	1230

All dimensions are given in mm

Technical data

Dimensions of models 20 and 25, vertical

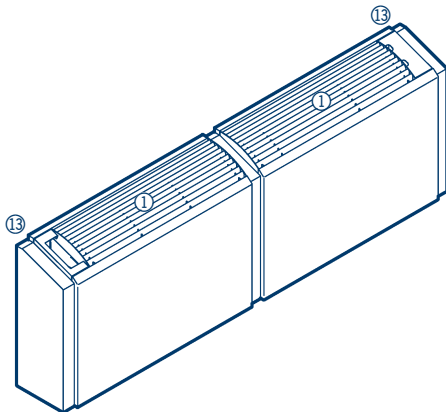

Vertical door air curtain with basic unit casing

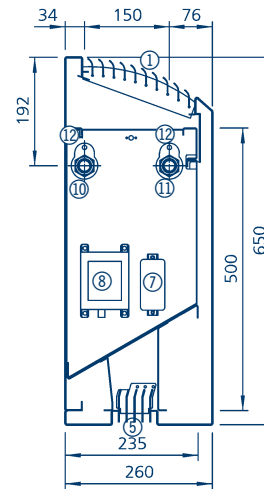

Cross-section through basic unit with casing

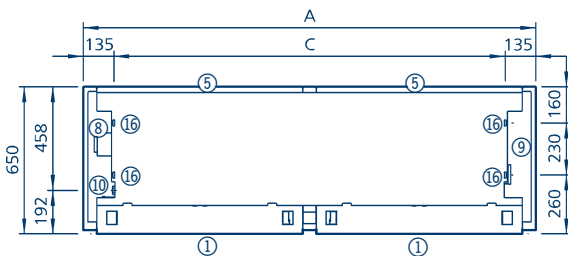

Basic unit casing, view from behind

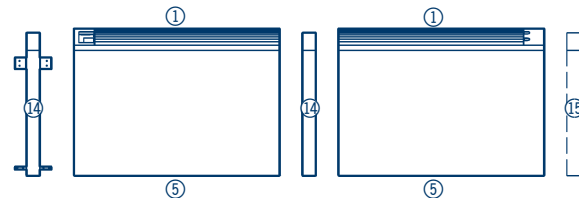

Casing extension

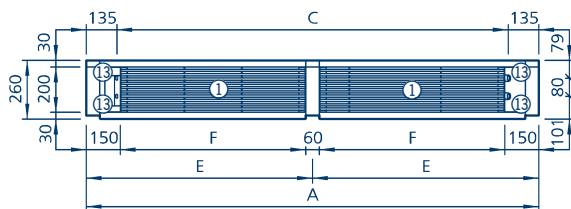

Basic unit with casing, top view

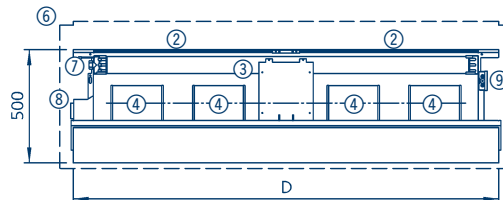

Basic unit without casing, front view
Model 20 shown

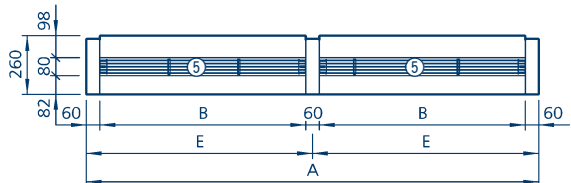

Basic unit casing, view of air outlet

- ① Inlet air grille
- ② Filter G2
- ③ Heat exchanger (copper/aluminium)
- ④ Radial fan
- ⑤ Leaving air rectifier
- ⑥ Casing outline
- ⑦ Electrical terminal box for thermoelectric shut-off valve
- ⑧ Transformer
- ⑨ Electrical connection
- ⑩ Flow connection 3/4"
- ⑪ Return connection 3/4"
- ⑫ Air vent
- ⑬ Fixing openings for fitting with wall or ceiling brackets
- ⑭ Connecting angle section for casing extension
- ⑮ Outline of basic unit casing end panel
- ⑯ Fixing openings for mounting directly onto the wall

Model	20	25
A	2000	2500
B	910	1160
C	1730	2230
D	1880	2380
E	1000	1250
F	820	1070

All dimensions are given in mm

Technical data

Dimensions of models 20, 25 and 30, standing

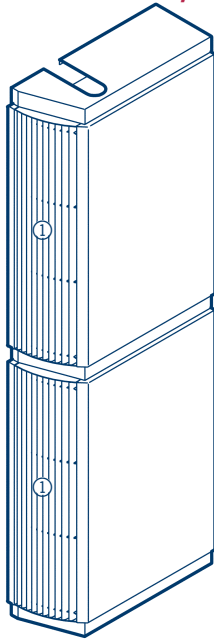

Door air curtain, standing with basic unit casing, models 20, 25, 30

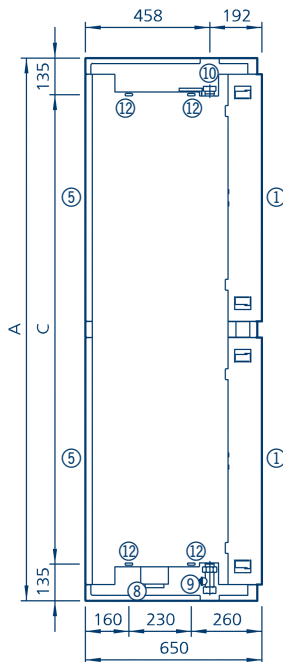

Basic unit with casing, view from behind, models 20, 25

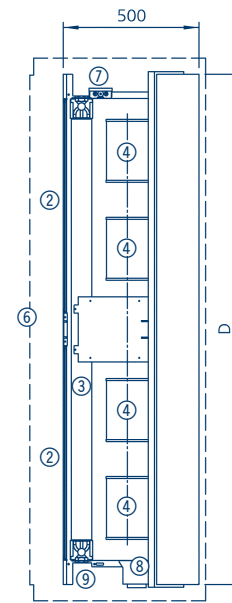

Basic unit without casing, front view, models 20, 25
Model 20 shown

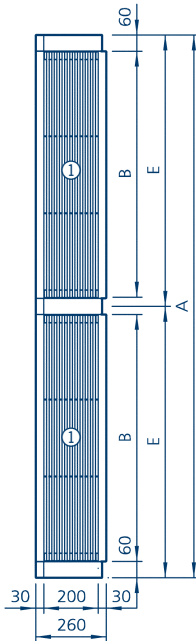

Basic unit casing, view of air inlet, models 20, 25, 30

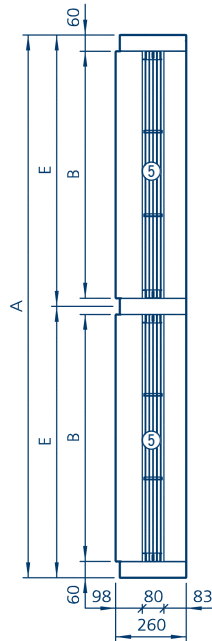

Basic unit casing, view of air outlet, models 20, 25, 30

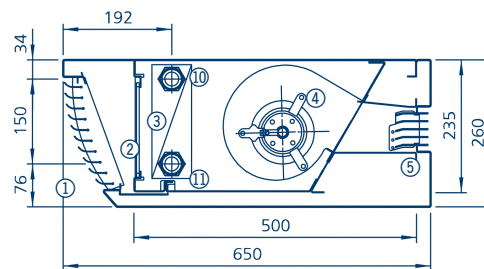

Cross-section through basic unit with casing

Shown positioned on left side of doorway

- ① Inlet air grille
- ② Filter G2
- ③ Heat exchanger (copper/aluminium)
- ④ Radial fan
- ⑤ Leaving air rectifier
- ⑥ Casing outline

- ⑦ Electrical junction box for thermoelectric shut-off valve
- ⑧ Transformer
- ⑨ Electrical connection
- ⑩ Flow connection 1"
- ⑪ Return connection 1"
- ⑫ Fixing holes

Model	20	25	30
A	2000	2500	2940
B	910	1160	1380
C	1730	2230	*
D	1880	2380	*
E	1000	1250	1470

All dimensions are given in mm

*For dimensions of model 30 see table p 28

Dimensions of models 30 and 35, standing

Unit shown positioned on the right-hand side of the doorway

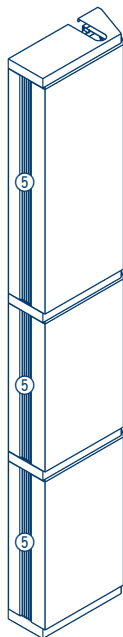

Model 35

Standing door air curtain with basic unit casing, model 35

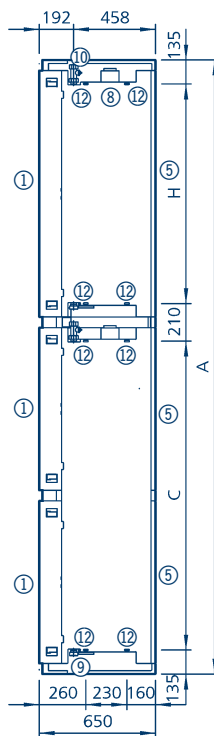

Basic unit with casing, view from behind, models 30 and 35

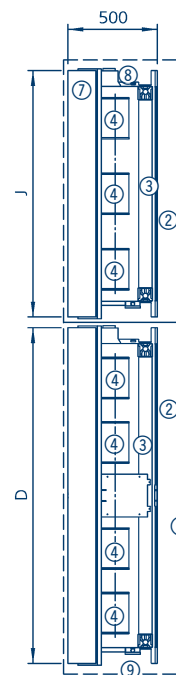

Basic unit without casing, front view, models 30 and 35

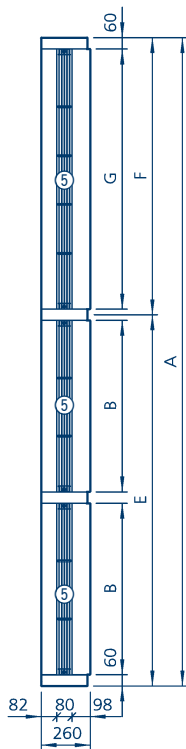

Basic unit casing, view of air outlet, model 35

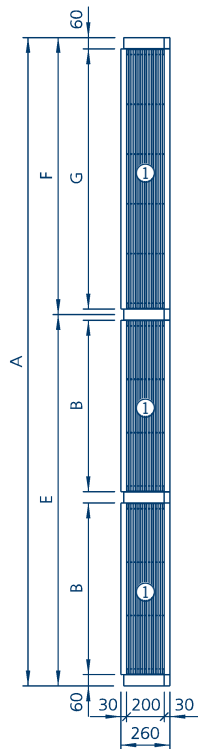

Basic unit casing, view of air inlet, model 35

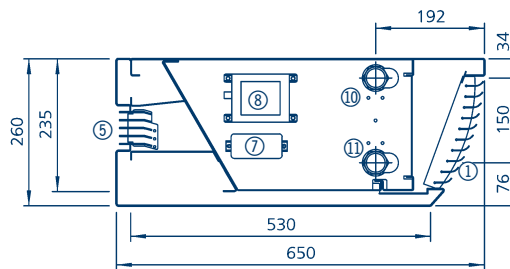

Basic unit with casing, top view

Refer to p. 36 for further views of model 30

Model	30	35
A	*	3440
B	*	910
C	1230	1730
D	1380	1880
E	*	1970
F	-	1470
G	-	1380
H	1230	1230
J	1380	1380

- ① Inlet air grille
- ② Filter G2
- ③ Heat exchanger (copper/aluminium)
- ④ Radial fan
- ⑤ Leaving air rectifier
- ⑥ Casing outline
- ⑦ Electrical terminal box for thermoelectric shut-off valve

- ⑧ Transformer
- ⑨ Electrical connection
- ⑩ Flow connection 1"
- ⑪ Return connection 1"
- ⑫ Fixing holes

All dimensions are given in mm

*For dimensions of model 30 see table p 27

Technical data

Dimensions of model sizes 10, 15, 20, 25, without heat exchanger, horizontal

Dimensions of model sizes 10,15, 20 and 25, without heat exchanger, horizontal

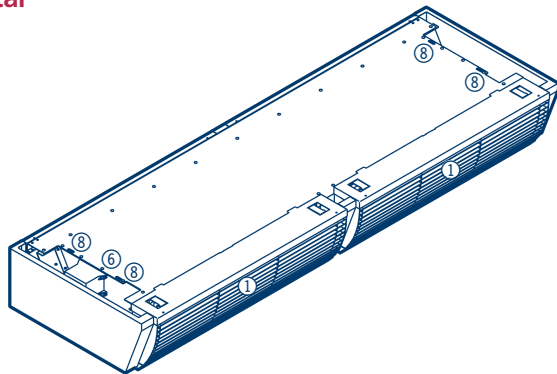

Door air curtain, horizontal with basic unit casing

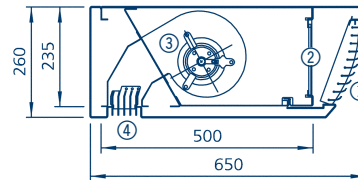

Cross-section through basic unit with casing

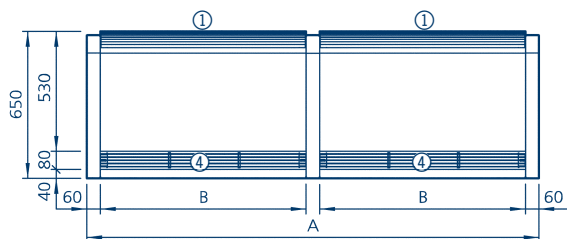

Basic unit casing, view from below

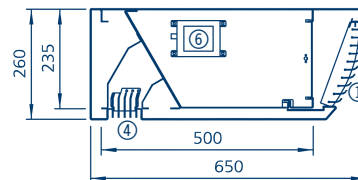

Side view through basic unit with casing

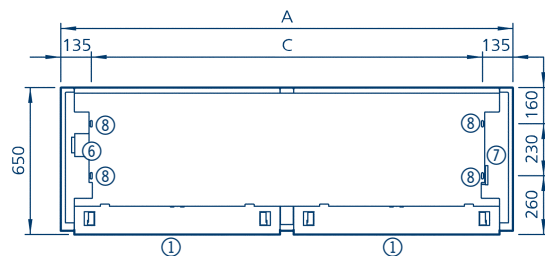

Top view of basic unit with casing

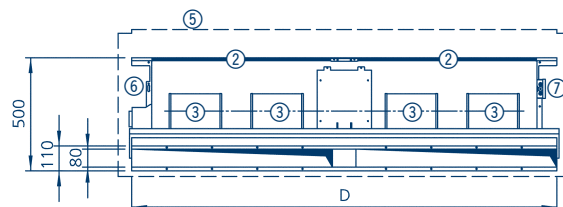

Basic unit with casing, view from below

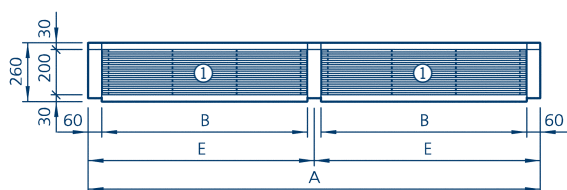

Basic unit casing, view of air inlet

- ① Inlet air grille
- ② Filter G2
- ③ Radial fan
- ④ Outlet air rectifier
- ⑤ Casing outline
- ⑥ Transformer
- ⑦ Electrical connection
- ⑧ Fixing holes for wall or ceiling brackets

All illustrations show model size 20 by way of example. Dimensions of other model sizes are shown in the Vario Door air curtain catalogue on pages 23-24

Model	10	15	20	25
A	1000	1500	2000	2500
B	880	1380	910	1160
C	730	1230	1730	2230
D	880	1380	1880	2380
E	-	-	1000	1250

All dimensions are given in mm

Technical data

Heat outputs for model size 10 • horizontal and vertical

Vario Door air curtain 10			horizontal					vertical				
Basic unit	Type		110330					110331				
Basic unit casing	Type		110800					110801				
Casing extension	Type		110810					110811				
Dimensions (incl. casing)	Length	mm	1000					1000				
	Height	mm	260					650				
	Depth	mm	650					260				
Max. discharge height H _{max} ¹⁾	m		2.3 - 3.0					2.3 - 3.0				
Max. door width	m		1.0					1.0				
Weight without/with casing	kg		33/55					33/55				
Water content	l		1.0					1.0				
Connections	inch		3/4"					3/4"				
Switching stage ²⁾			5		4		3		2		1	
Air volume	m ³ /h		1390		1220		1050		920		600	
Electrical power consumption ³⁾	W		392		313		238		202		113	
Current consumption ³⁾	A		1,68		1,35		1,05		0,91		0,54	
Sound pressure level -at a distance of 3m	dB(A)		57		54		50		47		36	
Heating medium	Entering air temp. t ₁ [°C]	Heat outputs										
		Q [W]	t ₁₂ [°C]	Q [W]	t ₁₂ [°C]	Q [W]	t ₁₂ [°C]	Q [W]	t ₁₂ [°C]	Q [W]	t ₁₂ [°C]	
LPWW 55/45 °C	14	7083	28,7	6680	29,8	6226	31,1	5829	32,3	4622	36,3	
	16	6638	29,9	6261	30,9	5835	32,2	5463	33,3	4332	37,0	
	18	6194	31,0	5842	32,0	5445	33,2	5098	34,2	4042	37,7	
	20	5751	32,2	5424	33,1	5055	34,2	4733	35,1	3753	38,4	
	22	5308	33,3	5006	34,1	4666	35,1	4368	36,0	3464	39,1	
LPHW 70/55 °C	14	9596	34,0	9050	35,4	8435	37,2	7897	38,8	6262	44,2	
	16	9146	35,1	8626	36,6	8040	38,3	7527	39,8	5968	44,9	
	18	8695	36,3	8201	37,7	7644	39,3	7156	40,7	5674	45,7	
	20	8244	37,4	7775	38,7	7247	40,3	6784	41,7	5380	46,4	
	22	7792	38,6	7348	39,8	6849	41,3	6412	42,6	5085	47,1	
LPHW 70/60 °C	14	10417	35,7	9825	37,3	9157	39,2	8573	40,9	6798	46,7	
	16	9973	36,9	9405	38,4	8767	40,3	8207	41,9	6508	47,5	
	18	9528	38,0	8986	39,5	8376	41,3	7841	42,9	6218	48,3	
	20	9083	39,2	8567	40,7	7985	42,4	7475	43,9	5928	49,1	
	22	8639	40,4	8147	41,8	7594	43,4	7109	44,9	5637	49,8	
LPHW 75/65 °C	14	11527	38,0	10871	39,8	10133	41,9	9486	43,8	7522	50,2	
	16	11083	39,2	10453	40,9	9743	43,0	9121	44,8	7233	51,0	
	18	10639	40,4	10034	42,0	9353	44,0	8756	45,8	6943	51,8	
	20	10195	41,6	9615	43,2	8962	45,1	8390	46,8	6653	52,6	
	22	9750	42,8	9196	44,3	8571	46,2	8024	47,8	6363	53,4	
LPHW 82/71 °C	14	12966	41,0	12229	43,0	11398	45,4	10671	47,5	8462	54,8	
	16	12524	42,2	11812	44,1	11009	46,5	10307	48,6	8173	55,6	
	18	12081	43,4	11394	45,3	10620	47,6	9942	49,6	7884	56,4	
	20	11638	44,6	10976	46,5	10231	48,7	9578	50,6	7595	57,2	
	22	11194	45,8	10558	47,6	9841	49,7	9212	51,6	7305	58,0	
LPHW 90/70 °C	20	11924	45,2	11246	47,1	10482	49,4	9813	51,4	7781	58,1	

Technical data

¹⁾With average to good pressure conditions/requirements, see pages 16 and 17²⁾With 3-stage switches, any 3 of the 5 stages can be selected³⁾For measuring values, see information on p 10

Article no. for DataNorm/EDV entry: 151 000 _ (insert type)

Heat outputs for model size 15 • horizontal and vertical

Vario Door air curtain 15			horizontal					vertical				
Basic unit	Type		115330					115331				
Basic unit casing	Type		115800					115801				
Casing extension	Type		115810					115811				
Dimensions (incl. casing)	Length	mm	1500					1500				
	Height	mm	260					650				
	Depth	mm	650					260				
Max. discharge height H _{max} ¹⁾	m		2.3 - 3.0					2.3 - 3.0				
Max. door width	m		1.5					1.5				
Weight without/with casing	kg		50/83					50/83				
Water content	l		1.8					1.8				
Connections	inch		3/4"					3/4"				
Switching stage ²⁾			5		4		3		2		1	
Air volume	m ³ /h		2130		1880		1610		1400		930	
Electrical power consumption ³⁾	W		573		456		346		298		164	
Current consumption ³⁾	A		2,48		1,98		1,51		1,32		0,78	
Sound pressure level- at a distance of 3m	dB(A)		58		55		51		48		37	
Heating medium	Entering air temp. t ₁ [°C]	Heat outputs										
		Q [W]	t ₁₂ [°C]	Q [W]	t ₁₂ [°C]	Q [W]	t ₁₂ [°C]	Q [W]	t ₁₂ [°C]	Q [W]	t ₁₂ [°C]	
LPWW 55/45 °C	14	12060	30,4	11074	31,0	9941	31,8	9008	32,6	6692	34,8	
	16	11304	31,4	10379	32,0	9318	32,8	8443	33,5	6272	35,6	
	18	10548	32,5	9685	33,1	8695	33,8	7878	34,5	5853	36,4	
	20	9793	33,5	8992	34,1	8072	34,7	7314	35,4	5434	37,2	
	22	9038	34,6	8299	35,1	7450	35,7	6751	36,3	5015	38,0	
LPHW 70/55 °C	14	16340	36,2	15003	37,1	13469	38,2	12204	39,2	9067	42,2	
	16	15574	37,3	14300	38,1	12838	39,2	11632	40,2	8642	43,0	
	18	14806	38,3	13595	39,1	12205	40,2	11059	41,1	8216	43,8	
	20	14038	39,4	12889	40,2	11571	41,1	10485	42,0	7789	44,6	
	22	13267	40,4	12182	41,2	10936	42,1	9909	42,9	7362	45,4	
LPHW 70/60 °C	14	17738	38,1	16287	39,0	14622	40,2	13249	41,4	9843	44,6	
	16	16981	39,2	15592	40,1	13998	41,3	12683	42,3	9423	45,5	
	18	16224	40,3	14897	41,2	13374	42,3	12118	43,3	9003	46,3	
	20	15467	41,4	14202	42,2	12750	43,3	11552	44,3	8583	47,1	
	22	14710	42,4	13507	43,3	12125	44,3	10987	45,2	8162	48,0	
LPHW 75/65 °C	14	19628	40,6	18023	41,7	16180	43,0	14660	44,3	10892	47,8	
	16	18873	41,8	17329	42,8	15557	44,1	14096	45,3	10472	48,7	
	18	18117	42,9	16635	43,9	14934	45,1	13531	46,3	10053	49,6	
	20	17360	44,0	15940	44,9	14310	46,1	12966	47,2	9633	50,5	
	22	16603	45,1	15245	46,0	13686	47,1	12401	48,2	9213	51,3	
LPHW 82/71 °C	14	22079	44,0	20273	45,2	18200	46,7	16491	48,0	12252	52,1	
	16	21326	45,1	19582	46,3	17579	47,7	15928	49,1	11834	53,0	
	18	20572	46,2	18889	47,4	16958	48,8	15365	50,1	11415	53,9	
	20	19817	47,4	18196	48,5	16335	49,8	14801	51,1	10996	54,8	
	22	19062	48,5	17503	49,5	15713	50,9	14237	52,1	10577	55,6	
LPHW 90/70 °C	20	20304	48,0	18644	49,2	16737	50,6	15165	51,9	11267	55,6	

Technical data

¹⁾With average to good pressure conditions/requirements, see pages 16 and 17

²⁾With 3-stage switches, any 3 of the 5 stages can be selected

³⁾For measuring values, see information on p 10

Article no. for DataNorm/EDV entry: 151 000 (Insert type)

Heat outputs for model size 20 • horizontal, vertical and standing

Vario Door air curtain 20			horizontal		vertical		standing				
Basic unit	Type		120330		120331		120332				
Basic unit casing	Type		120800		120801		120802				
Casing extension	Type		120810		120811		---				
Dimensions (incl. casing)	Length	mm	2000		2000		650				
	Height	mm	260		650		2000				
	Depth	mm	650		260		260				
H _{max} ¹⁾ , (W _{max}) ¹⁾²⁾ Max. door width (door height)	m		2.3 - 3.0		2.3 - 3.0		(2.3 - 3.0)				
	m		2.0		2.0		(2.0)				
Weight without/with casing	kg		68/106		68/106		68/106				
Water content	l		2.6		2.6		2.6				
Connections	inch		3/4"		3/4"		1"				
Switching stage ³⁾			5		4		3		2		1
Air volume	m ³ /h		2820		2480		2140		1850		1210
Electrical power consumption ⁴⁾	W		754		598		454		393		215
Current consumption ⁴⁾	A		3,27		2,60		1,97		1,73		1,01
Sound pressure level- at a distance of 3m	dB(A)		59		56		53		49		39
Heating medium	Entering air temp. t ₁ [°C]	Heat outputs									
		Q [W]	t _{1,2} [°C]	Q [W]	t _{1,2} [°C]	Q [W]	t _{1,2} [°C]	Q [W]	t _{1,2} [°C]	Q [W]	t _{1,2} [°C]
LPWW 55/45 °C	14	16811	31,2	15372	31,9	13855	32,7	12479	33,5	9123	35,8
	16	15757	32,2	14408	32,9	12986	33,6	11696	34,4	8551	36,5
	18	14703	33,2	13444	33,9	12118	34,6	10914	35,3	7979	37,3
	20	13651	34,2	12482	34,8	11250	35,5	10133	36,1	7408	38,0
	22	12599	35,2	11520	35,7	10384	36,4	9352	37,0	6837	38,7
LPHW 70/55 °C	14	22777	37,3	20827	38,3	18772	39,4	16907	40,4	12360	43,5
	16	21709	38,4	19850	39,3	17892	40,3	16115	41,3	11781	44,3
	18	20639	39,4	18872	40,3	17010	41,2	15321	42,2	11200	45,1
	20	19568	40,4	17892	41,2	16127	42,2	14525	43,1	10619	45,8
	22	18494	41,4	16911	42,2	15242	43,1	13728	44,0	10036	46,5
LPHW 70/60 °C	14	24726	39,3	22609	40,3	20379	41,5	18354	42,7	13418	46,1
	16	23671	40,4	21645	41,4	19509	42,5	17571	43,6	12846	46,9
	18	22616	41,4	20680	42,4	18639	43,5	16788	44,5	12273	47,7
	20	21560	42,5	19714	43,4	17769	44,4	16004	45,4	11700	48,4
	22	20505	43,5	18749	44,4	16899	45,4	15221	46,3	11127	49,2
LPHW 75/65 °C	14	27361	42,0	25018	43,2	22550	44,5	20310	45,7	14848	49,5
	16	26308	43,1	24055	44,2	21682	45,5	19528	46,7	14276	50,3
	18	25254	44,2	23091	45,2	20813	46,4	18746	47,6	13704	51,1
	20	24199	45,2	22127	46,2	19944	47,4	17963	48,6	13132	51,9
	22	23144	46,3	21162	47,2	19074	48,4	17180	49,5	12559	52,7
LPHW 82/71 °C	14	30777	45,5	28142	46,8	25366	48,3	22846	49,7	16702	53,9
	16	29727	46,6	27182	47,9	24500	49,3	22067	50,7	16132	54,8
	18	28676	47,7	26221	48,9	23634	50,3	21287	51,6	15562	55,6
	20	27624	48,8	25259	50,0	22767	51,3	20506	52,6	14991	56,4
	22	26571	49,9	24296	51,0	21899	52,3	19724	53,5	14419	57,3
LPHW 90/70 °C	20	28303	49,5	25880	50,7	23327	52,1	21010	53,4	15359	57,3

Technical data

¹⁾H_{max} = max. discharge height, W_{max} = max. discharge width, with average to good pressure conditions/requirements, see p 16 and 17

²⁾If the max. discharge width (wide doorway) is exceeded, we would recommend positioning a unit on either side of the door.

³⁾With 3-stage switches, any 3 of the 5 stages can be selected

⁴⁾For measuring values, see information on p 10

Article no. for DataNorm/EDV entry: 151 000 (Insert type)

Heat outputs for model size 25 • horizontal, vertical and standing

Vario Door air curtain 25			horizontal		vertical		standing				
Basic unit	Type		125330		125331		125332				
Basic unit casing	Type		125800		125801		125802				
Casing extension	Type		125810		125811		---				
Dimensions (incl. casing)	Length	mm	2500		2500		650				
	Height	mm	260		650		2500				
	Depth	mm	650		260		260				
H _{max} ¹⁾ , (W _{max}) ¹⁾²⁾ Max. door width (door width)	m		2.3 - 3.0		2.3 - 3.0		(2.3 - 3.0)				
	m		2.5		2.5		(2.5)				
Weight without/with casing	kg		87/134		87/134		87/134				
Water content	l		3.5		3.5		3,5				
Connections	Zoll		3/4"		3/4"		1"				
Switching stage ³⁾			5		4		3		2		1
Air volume	m ³ /h		4000		3450		2980		2620		1660
Electrical power consumption ⁴⁾	W		1091		873		658		567		305
Current consumption ⁴⁾	A		4,77		3,81		2,87		2,51		1,44
Sound pressure level- at a distance of 3m	dB(A)		60		56		52		49		40
Heating medium	Entering air temp. t ₁ [°C]	Heat outputs									
		Q [W]	t ₁₂ [°C]	Q [W]	t ₁₂ [°C]	Q [W]	t ₁₂ [°C]	Q [W]	t ₁₂ [°C]	Q [W]	t ₁₂ [°C]
LPWW 55/45 °C	14	23518	31,0	21227	31,8	19147	32,6	17466	33,3	12488	35,7
	16	22043	32,0	19896	32,8	17946	33,5	16371	34,2	11705	36,5
	18	20569	33,0	18565	33,7	16746	34,4	15276	35,0	10922	37,2
	20	19096	34,0	17236	34,7	15547	35,3	14183	35,9	10140	38,0
	22	17625	35,0	15908	35,6	14349	36,2	13090	36,8	9359	38,7
LPHW 70/55 °C	14	31864	37,0	28759	38,1	25941	39,2	23665	40,1	16920	43,5
	16	30370	38,1	27411	39,1	24725	40,1	22555	41,0	16126	44,2
	18	28873	39,1	26060	40,1	23507	41,1	21444	41,9	15332	45,0
	20	27374	40,1	24707	41,1	22286	42,0	20330	42,8	14536	45,8
	22	25872	41,1	23352	42,0	21064	42,9	19215	43,7	13738	46,5
LPHW 70/60 °C	14	34591	39,0	31221	40,2	28162	41,3	25690	42,3	18368	46,0
	16	33115	40,1	29889	41,2	26960	42,3	24594	43,3	17584	46,8
	18	31639	41,1	28556	42,2	25758	43,3	23497	44,2	16800	47,6
	20	30162	42,2	27223	43,2	24556	44,2	22401	45,1	16016	48,4
	22	28685	43,2	25890	44,2	23353	45,2	21304	46,1	15232	49,1
LPHW 75/65 °C	14	38276	41,7	34548	42,9	31162	44,2	28427	45,4	20325	49,4
	16	36803	42,7	33218	44,0	29963	45,2	27333	46,3	19542	50,2
	18	35328	43,8	31887	45,0	28762	46,2	26238	47,3	18759	51,0
	20	33853	44,9	30555	46,0	27561	47,2	25142	48,2	17976	51,8
	22	32377	45,9	29223	47,1	26359	48,2	24046	49,2	17192	52,6
LPHW 82/71 °C	14	43056	45,1	38861	46,6	35053	48,0	31977	49,3	22863	53,8
	16	41587	46,2	37535	47,6	33857	49,0	30886	50,3	22083	54,7
	18	40117	47,3	36208	48,7	32660	50,0	29794	51,3	21302	55,5
	20	38645	48,4	34880	49,7	31462	51,1	28701	52,2	20520	56,4
	22	37171	49,5	33550	50,8	30263	52,0	27607	53,2	19738	57,2
LPHW 90/70 °C	20	39595	49,1	35737	50,5	32236	51,8	29406	53,0	21025	57,3

Technical data

¹⁾H_{max} = max. discharge height, W_{max} = max. discharge width, with average to good pressure conditions/requirements, see p 16 and 17

²⁾If the max. discharge width (wide doorway) is exceeded, we would recommend positioning a unit on either side of the door.

³⁾With 3-stage switches, any 3 of the 5 stages can be selected

⁴⁾For measuring values, see information on p 10

Article no. for DataNorm/EDV entry: 151 000 _[insert type]



Heat outputs for model size 30 • standing

Vario Door air curtain 30			standing									
Basic unit	Type		130332									
Basic unit casing	Type		130802									
Dimensions (incl. casing)	Length	mm	650									
	Height	mm	3000									
	Depth	mm	260									
Max. discharge width W_{max} ¹⁾²⁾	m		2.3 - 3.0									
Max. door height	m		3.0									
Weight without/with casing	kg		100/166									
Water content	l		3.6									
Connections	Zoll		1"									
Switching stage ³⁾			5	4	3	2	1					
Air volume	m ³ /h		4260	3760	3220	2800	1860					
Electrical power consumption ⁴⁾	W		1091	873	658	567	305					
Current consumption ⁴⁾	A		4,77	3,81	2,87	2,51	1,44					
Sound pressure level- at a distance of 3m	dB(A)		61	57	54	50	41					
Heating medium	Lufteintritts-temp. t_{L1} [°C]	Heat outputs										
		Q [W]	t_{L2} [°C]	Q [W]	t_{L2} [°C]	Q [W]	t_{L2} [°C]	Q [W]	t_{L2} [°C]	Q [W]	t_{L2} [°C]	
LPWW 55/45 °C	14	24120	30,4	22147	31,0	19882	31,8	18015	32,6	13384	34,8	
	16	22608	31,4	20758	32,0	18636	32,8	16885	33,5	12545	35,6	
	18	21096	32,5	19370	33,1	17390	33,8	15756	34,5	11706	36,4	
	20	19586	33,5	17983	34,1	16145	34,7	14628	35,4	10868	37,2	
	22	18077	34,6	16598	35,1	14901	35,7	13501	36,3	10031	38,0	
LPHW 70/55 °C	14	32680	36,2	30007	37,1	26938	38,2	24408	39,2	18134	42,2	
	16	31148	37,3	28600	38,1	25675	39,2	23264	40,2	17284	43,0	
	18	29613	38,3	27191	39,1	24410	40,2	22117	41,1	16432	43,8	
	20	28075	39,4	25779	40,2	23143	41,1	20969	42,0	15579	44,6	
	22	26535	40,4	24364	41,2	21873	42,1	19819	42,9	14724	45,4	
LPHW 70/60 °C	14	35477	38,1	32575	39,0	29244	40,2	26497	41,4	19686	44,6	
	16	33963	39,2	31185	40,1	27996	41,3	25367	42,3	18846	45,5	
	18	32449	40,3	29795	41,2	26748	42,3	24236	43,3	18006	46,3	
	20	30934	41,4	28404	42,2	25499	43,3	23104	44,3	17165	47,1	
	22	29420	42,4	27013	43,3	24251	44,3	21973	45,2	16325	48,0	
LPHW 75/65 °C	14	39257	40,6	36046	41,7	32360	43,0	29320	44,3	21783	47,8	
	16	37746	41,8	34658	42,8	31114	44,1	28192	45,3	20945	48,7	
	18	36233	42,9	33269	43,9	29867	45,1	27062	46,3	20106	49,6	
	20	34720	44,0	31880	44,9	28620	46,1	25932	47,2	19266	50,5	
	22	33206	45,1	30490	46,0	27372	47,1	24801	48,2	18426	51,3	
LPHW 82/71 °C	14	44158	44,0	40546	45,2	36400	46,7	32981	48,0	24503	52,1	
	16	42652	45,1	39163	46,3	35158	47,7	31856	49,1	23667	53,0	
	18	41144	46,2	37779	47,4	33915	48,8	30730	50,1	22831	53,9	
	20	39634	47,4	36392	48,5	32671	49,8	29603	51,1	21993	54,8	
	22	38123	48,5	35005	49,5	31425	50,9	28474	52,1	21155	55,6	
LPHW 90/70 °C	20	40609	48,0	37287	49,2	33474	50,6	30330	51,9	22534	55,6	

Technical data

¹⁾ H_{max} = max. discharge height, W_{max} = max. discharge width, with average to good pressure conditions/requirements, see p 16 and 17

²⁾If the max. discharge width (wide doorway) is exceeded, we would recommend positioning a unit on either side of the door.

³⁾With 3-stage switches, any 3 of the 5 stages can be selected

⁴⁾For measuring values, see information on p 10

Article no. for DataNorm/EDV entry: 151 000 _[insert_type]

Heat outputs for model size 35 • standing

Door air curtains 35			standing									
Basic unit	Type		135332									
Basic unit casing	Type		135802									
Dimensions (incl. casing)	Length	mm	650									
	Height	mm	3500									
	Depth	mm	260									
Max. discharge width W_{max} ¹⁾²⁾	m		2,3 - 3,0									
Max. door height	m		3,5									
Weight without/with casing	kg		118/189									
Water content	l		4,4									
Connections	inch		1"									
Switching stage ³⁾			5	4	3	2	1					
Air volume	m ³ /h		4950	4360	3750	3250	2140					
Electrical power consumption ⁴⁾	W		1327	1054	800	691	379					
Current consumption ⁴⁾	A		5,75	4,58	3,48	3,05	1,79					
Sound pressure level- at a distance of 3m	dB(A)		62	58	55	51	42					
Heating medium	Entering air temp. t_{1} [°C]	Heat outputs										
		Q [W]	$t_{1,2}$ [°C]	Q [W]	$t_{1,2}$ [°C]	Q [W]	$t_{1,2}$ [°C]	Q [W]	$t_{1,2}$ [°C]	Q [W]	$t_{1,2}$ [°C]	
LPWW 55/45 °C	14	28871	30,9	26445	31,5	23796	32,3	21487	33,1	15815	35,4	
	16	27061	31,9	24787	32,5	22304	33,3	20139	34,0	14823	36,1	
	18	25251	32,9	23130	33,5	20813	34,2	18792	34,9	13832	36,9	
	20	23443	33,9	21474	34,5	19323	35,2	17447	35,8	12842	37,6	
	22	21637	34,9	19819	35,4	17834	36,1	16103	36,7	11852	38,4	
LPHW 70/55 °C	14	39117	36,8	35830	37,8	32241	38,8	29111	39,9	21427	42,9	
	16	37283	37,9	34150	38,8	30730	39,8	27747	40,8	20423	43,7	
	18	35446	38,9	32467	39,8	29215	40,8	26379	41,7	19416	44,5	
	20	33605	40,0	30782	40,8	27698	41,7	25010	42,6	18408	45,3	
	22	31762	41,0	29093	41,7	26179	42,7	23638	43,5	17398	46,1	
LPHW 70/60 °C	14	42465	38,8	38897	39,8	35000	41,0	31603	42,1	23261	45,4	
	16	40653	39,9	37237	40,8	33507	42,0	30255	43,1	22269	46,2	
	18	38840	40,9	35577	41,9	32013	43,0	28906	44,0	21276	47,1	
	20	37028	42,0	33916	42,9	30519	43,9	27557	44,9	20283	47,9	
	22	35215	43,0	32256	43,9	29025	44,9	26207	45,9	19290	48,7	
LPHW 75/65 °C	14	46989	41,4	43041	42,5	38730	43,8	34970	45,1	25740	48,8	
	16	45180	42,5	41384	43,6	37239	44,9	33624	46,1	24749	49,6	
	18	43370	43,6	39726	44,6	35747	45,9	32277	47,0	23757	50,5	
	20	41559	44,7	38067	45,7	34254	46,9	30929	48,0	22765	51,3	
	22	39747	45,8	36407	46,7	32760	47,8	29580	48,9	21772	52,1	
LPHW 82/71 °C	14	52856	44,9	48415	46,1	43566	47,6	39337	49,0	28953	53,1	
	16	51053	46,0	46764	47,2	42080	48,6	37995	50,0	27966	54,0	
	18	49248	47,1	45110	48,3	40592	49,7	36652	51,0	26977	54,9	
	20	47441	48,2	43455	49,3	39102	50,7	35307	52,0	25987	55,7	
	22	45633	49,3	41799	50,4	37612	51,7	33961	52,9	24997	56,6	
LPHW 90/70 °C	20	48608	48,9	44523	50,0	40064	51,4	36175	52,7	26626	56,6	

Technische Daten

¹⁾H_{max} = max. discharge height, W_{max} = max. discharge width, with average to good pressure conditions/requirements, see p 16 and 17

²⁾If the max. discharge width (wide doorway) is exceeded, we would recommend positioning a unit on either side of the door.

³⁾With 3-stage switches, any 3 of the 5 stages can be selected

⁴⁾For measuring values, see information on p 10

Article no. for DataNorm/EDV entry: 151 000 (Insert type)

Horizontal model, without heat exchanger, model sizes 10, 15, 20, 25

Vario Door air curtain for cold stores			Model 10, horizontal					Model 15, horizontal				
Basic unit	Type		110335					115335				
Basic unit casing	Type		110800					115800				
Casing extension	Type		110810					115810				
Dimensions (incl. casing)	Length	mm	1000					1500				
	Height	mm	260					260				
	Depth	mm	650					650				
Max. discharge height $H_{max}^{1)}$	m		2.3 - 3.0					2.3 - 3.0				
Max. door width	m		1.0					1.5				
Weight without/with casing	kg		30/52					46/79				
Switching stage ²⁾			5	4	3	2	1	5	4	3	2	1
Air volume, total	m ³ /h		1390	1220	1050	920	600	2130	1880	1610	1400	930
Electrical power consumption ³⁾	W		392	313	238	202	113	573	456	346	298	164
Current consumption ³⁾	A		1,68	1,35	1,05	0,91	0,54	2,48	1,98	1,51	1,32	0,78
Sound pressure level- at a distance of 3m	dB(A)		57	54	50	47	36	58	55	51	48	37

Vario Door air curtain for cold stores			Model 20, horizontal					Model 25, horizontal				
Basic unit	Type		120335					125335				
Basic unit casing	Type		120800					125800				
Casing extension	Type		120810					125810				
Dimensions (incl. casing)	Length	mm	2000					2500				
	Height	mm	260					260				
	Depth	mm	650					650				
Max. discharge height $H_{max}^{1)}$	m		2.3 - 3.0					2.3 - 3.0				
Max. door width	m		2.0					2.5				
Weight without/with casing	kg		62/100					75/126				
Switching stage ²⁾			5	4	3	2	1	5	4	3	2	1
Air volume, total	m ³ /h		2820	2480	2140	1850	1210	4000	3450	2980	2620	1660
Electrical power consumption ³⁾	W		754	598	454	393	215	1091	873	658	567	305
Current consumption ³⁾	A		3,27	2,60	1,97	1,73	1,01	4,77	3,81	2,87	2,51	1,44
Sound pressure level- at a distance of 3m	dB(A)		59	56	53	49	39	60	56	52	49	40

Technical data

¹⁾With average to good pressure conditions/requirements, see pages 16 and 17

²⁾With 3-stage switches, any 3 of the 5 stages can be selected

³⁾For measuring values, see information on p 10

Article no. for DataNorm/EDV entry: 151 000 _ (Insert type)

Qty.	Article no.	Description	Price/each	Total price																																																																																																										
pc.	151 000 1 10 330	<p>Vario Door air curtain basic unit Basic construction made of sendzimir galvanised steel metal with sound and heat insulation around the fan; air inlet through large, easily-removable filter, filter class G 2; maintenance-free; high-output heat exchanger, made of hollow copper pipes with aluminium fins, for heating up to a supply temperature of 90 °C and maximum 10 bar continuous operating pressure; with large radial fans, air intake on both sides and direct-driven, switched between 5 stages via a transformer, voltage 230 V/50 Hz; internal motor protection by thermal contacts, Motor protection class IP 44, Insulation class F; Heat exchanger connection 3/4"; 1" connection with standing model</p> <p>1 Vario Door air curtain</p> <p>330 Horizontal model 331 Vertical model 332 Standing model</p> <p>Vario door air curtain (incl. casing) dimensions:</p> <table border="0"> <tr> <td>10</td> <td>Model size 10: Horizontal model</td> <td>L x H x D: 1000 x 260 x 650 mm</td> </tr> <tr> <td></td> <td>Vertical model</td> <td>L x H x D: 1000 x 650 x 260 mm</td> </tr> <tr> <td>15</td> <td>Model size 15: Horizontal model</td> <td>L x H x D: 1500 x 260 x 650 mm</td> </tr> <tr> <td></td> <td>Vertical model</td> <td>L x H x D: 1500 x 650 x 260 mm</td> </tr> <tr> <td>20</td> <td>Model size 20: Horizontal model</td> <td>L x H x D: 2000 x 260 x 650 mm</td> </tr> <tr> <td></td> <td>Vertical model</td> <td>L x H x D: 2000 x 650 x 260 mm</td> </tr> <tr> <td></td> <td>Standing model</td> <td>L x H x D: 650 x 2000 x 260 mm</td> </tr> <tr> <td>25</td> <td>Model size 25: Horizontal model</td> <td>L x H x D: 2500 x 260 x 650 mm</td> </tr> <tr> <td></td> <td>Vertical model</td> <td>L x H x D: 2500 x 650 x 260 mm</td> </tr> <tr> <td></td> <td>Standing model</td> <td>L x H x D: 650 x 2500 x 260 mm</td> </tr> <tr> <td>30</td> <td>Model size 30: Standing model</td> <td>L x H x D: 650 x 3000 x 260 mm</td> </tr> <tr> <td>35</td> <td>Model size 35: Standing model</td> <td>L x H x D: 650 x 3500 x 260 mm</td> </tr> </table> <p>Technical data</p> <table border="0"> <tr> <td>Switching stage</td> <td>5</td> <td>4</td> <td>3</td> <td>2</td> <td>1</td> <td></td> </tr> <tr> <td>Air volume</td> <td>_____</td> <td>_____</td> <td>_____</td> <td>_____</td> <td>_____</td> <td>m³/h</td> </tr> <tr> <td>Power consumption</td> <td>_____</td> <td>_____</td> <td>_____</td> <td>_____</td> <td>_____</td> <td>W</td> </tr> <tr> <td>Current consumption Fan/Contr.</td> <td>_____</td> <td>_____</td> <td>_____</td> <td>_____</td> <td>_____</td> <td>A</td> </tr> <tr> <td>Sound pressure level</td> <td>_____</td> <td>_____</td> <td>_____</td> <td>_____</td> <td>_____</td> <td>dB(A)</td> </tr> <tr> <td>Heat output</td> <td>_____</td> <td>_____</td> <td>_____</td> <td>_____</td> <td>_____</td> <td>W</td> </tr> <tr> <td>Leaving air temperature</td> <td>_____</td> <td>_____</td> <td>_____</td> <td>_____</td> <td>_____</td> <td>°C</td> </tr> <tr> <td>Weight</td> <td>_____</td> <td>_____</td> <td>_____</td> <td>_____</td> <td>_____</td> <td>kg</td> </tr> <tr> <td>Heating medium LPHW</td> <td>_____ / _____</td> <td>_____ / _____</td> <td>_____ / _____</td> <td>_____ / _____</td> <td>_____ / _____</td> <td>°C</td> </tr> <tr> <td>Entering air temperature</td> <td>_____</td> <td>_____</td> <td>_____</td> <td>_____</td> <td>_____</td> <td>°C</td> </tr> </table> <p>Article group 1.51, Manufacturer Kampmann, Article no. 1510001_----- type 1_-----</p>	10	Model size 10: Horizontal model	L x H x D: 1000 x 260 x 650 mm		Vertical model	L x H x D: 1000 x 650 x 260 mm	15	Model size 15: Horizontal model	L x H x D: 1500 x 260 x 650 mm		Vertical model	L x H x D: 1500 x 650 x 260 mm	20	Model size 20: Horizontal model	L x H x D: 2000 x 260 x 650 mm		Vertical model	L x H x D: 2000 x 650 x 260 mm		Standing model	L x H x D: 650 x 2000 x 260 mm	25	Model size 25: Horizontal model	L x H x D: 2500 x 260 x 650 mm		Vertical model	L x H x D: 2500 x 650 x 260 mm		Standing model	L x H x D: 650 x 2500 x 260 mm	30	Model size 30: Standing model	L x H x D: 650 x 3000 x 260 mm	35	Model size 35: Standing model	L x H x D: 650 x 3500 x 260 mm	Switching stage	5	4	3	2	1		Air volume	_____	_____	_____	_____	_____	m ³ /h	Power consumption	_____	_____	_____	_____	_____	W	Current consumption Fan/Contr.	_____	_____	_____	_____	_____	A	Sound pressure level	_____	_____	_____	_____	_____	dB(A)	Heat output	_____	_____	_____	_____	_____	W	Leaving air temperature	_____	_____	_____	_____	_____	°C	Weight	_____	_____	_____	_____	_____	kg	Heating medium LPHW	_____ / _____	_____ / _____	_____ / _____	_____ / _____	_____ / _____	°C	Entering air temperature	_____	_____	_____	_____	_____	°C		
10	Model size 10: Horizontal model	L x H x D: 1000 x 260 x 650 mm																																																																																																												
	Vertical model	L x H x D: 1000 x 650 x 260 mm																																																																																																												
15	Model size 15: Horizontal model	L x H x D: 1500 x 260 x 650 mm																																																																																																												
	Vertical model	L x H x D: 1500 x 650 x 260 mm																																																																																																												
20	Model size 20: Horizontal model	L x H x D: 2000 x 260 x 650 mm																																																																																																												
	Vertical model	L x H x D: 2000 x 650 x 260 mm																																																																																																												
	Standing model	L x H x D: 650 x 2000 x 260 mm																																																																																																												
25	Model size 25: Horizontal model	L x H x D: 2500 x 260 x 650 mm																																																																																																												
	Vertical model	L x H x D: 2500 x 650 x 260 mm																																																																																																												
	Standing model	L x H x D: 650 x 2500 x 260 mm																																																																																																												
30	Model size 30: Standing model	L x H x D: 650 x 3000 x 260 mm																																																																																																												
35	Model size 35: Standing model	L x H x D: 650 x 3500 x 260 mm																																																																																																												
Switching stage	5	4	3	2	1																																																																																																									
Air volume	_____	_____	_____	_____	_____	m ³ /h																																																																																																								
Power consumption	_____	_____	_____	_____	_____	W																																																																																																								
Current consumption Fan/Contr.	_____	_____	_____	_____	_____	A																																																																																																								
Sound pressure level	_____	_____	_____	_____	_____	dB(A)																																																																																																								
Heat output	_____	_____	_____	_____	_____	W																																																																																																								
Leaving air temperature	_____	_____	_____	_____	_____	°C																																																																																																								
Weight	_____	_____	_____	_____	_____	kg																																																																																																								
Heating medium LPHW	_____ / _____	_____ / _____	_____ / _____	_____ / _____	_____ / _____	°C																																																																																																								
Entering air temperature	_____	_____	_____	_____	_____	°C																																																																																																								
	Required to complete article no. for DataNorm/EDV																																																																																																													

Specifications/Ordering

Qty.	Article no.	Description	Price/each	Total price
pc.	151 000	<p>1 10 800</p> <p>Basic unit casing for door air curtains made of steel metal; attractive, slimline housing design, simple to assemble, welded and smoothed corners with lateral recessed end sections, simple to remove for service and maintenance; powdercoated traffic white RAL 9016; rounded linear air inlet grille made of air stream-enhancing profiles, simple to remove for servicing the filter, powdercoated RAL 9006; outlet air rectifier in the air outlet for minimal turbulence and evenly designed air outlet, powdercoated RAL 9006;</p> <p>1 Vario Door air curtain</p> <p>800 Horizontal model 801 Vertical model 802 Standing model</p> <p>Vario door air curtain dimensions:</p> <p>10 Model size 10: Horizontal model L x H x D: 1000 x 260 x 650 mm Vertical model L x H x D: 1000 x 650 x 260 mm 15 Model size 15: Horizontal model L x H x D: 1500 x 260 x 650 mm Vertical model L x H x D: 1500 x 650 x 260 mm 20 Model size 20: Horizontal model L x H x D: 2000 x 260 x 650 mm Vertical model L x H x D: 2000 x 650 x 260 mm Standing model L x H x D: 650 x 2000 x 260 mm 25 Model size 25: Horizontal model L x H x D: 2500 x 260 x 650 mm Vertical model L x H x D: 2500 x 650 x 260 mm Standing model L x H x D: 650 x 2500 x 260 mm 30 Model size 30: Standing model L x H x D: 650 x 3000 x 260 mm 35 Model size 35: Standing model L x H x D: 650 x 3500 x 260 mm</p> <p>Article group 1.51, Manufacturer Kampmann, Article no. 1510001_ _ _ _ _ , Type 1_ _ _ _</p>		
pc.	151 000	<p>1 10 810</p> <p>Door air curtain casing extension manufactured from steel metal, powdercoated traffic white RAL 9016; elegant, slimline housing design, simple to assemble, welded and smoothed angles with lateral, recessed end sections, simple to remove for service and maintenance; powdercoated traffic white RAL 9016; with angled section connected to basic unit casing; rounded linear air inlet grille made of air stream-enhancing profiles, simple to remove for servicing the filter, powdercoated RAL 9006; outlet air rectifier in the outlet for minimal turbulence and evenly designed air outlet, powdercoated RAL 9006; suitable for connecting several models of horizontal and vertical door air curtains together with basic unit casing</p> <p>1 Vario Door air curtain</p> <p>810 Horizontal model 811 Vertical model</p> <p>Vario door air curtain dimensions</p> <p>10 Model size 10: Horizontal model L x H x D: 1000 x 260 x 650 mm Vertical model L x H x D: 1000 x 650 x 260 mm 15 Model size 15: Horizontal model L x H x D: 1500 x 260 x 650 mm Vertical model L x H x D: 1500 x 650 x 260 mm 20 Model size 20: Horizontal model L x H x D: 2000 x 260 x 650 mm Vertical model L x H x D: 2000 x 650 x 260 mm Standing model L x H x D: 650 x 2000 x 260 mm 25 Model size 25: Horizontal model L x H x D: 2500 x 260 x 650 mm Vertical model L x H x D: 2500 x 650 x 260 mm</p> <p>Article group 1.51, Manufacturer Kampmann, Article no. 1510001_ _ _ _ _ , Type 1_ _ _ _</p> <p>---</p>		
		Required to complete article no. for DataNorm/EDV		

Specifications/Ordering



Brackets • Steel metal accessories for use with suspended ceilings

Qty.	Article no.	Description	Price/each	Total price
set	151 000 1 00 8 9 0	<p>Wall brackets for door air curtains made of sendzimir galvanised steel metal, powdercoated traffic white RAL 9016; adjustable with telescopic rails and threaded rods, consisting of 2 fixing angles with U-rails and screws, 4 threaded rods M8 x 500 mm with bolts, 2 telescopic rails and 2 screw covers</p> <p>1 for Vario Door air curtains</p> <p>0 for horizontal models</p> <p>1 for vertical models</p> <p>Article group 1.51, Manufacturer Kampmann, Article no. 15100010089_ . Type 10089_</p>	required per door air curtain basic unit	
set	151 000 1 00 8 9 5	<p>Ceiling brackets for door air curtains made of sendzimir galvanised steel metal, powdercoated traffic white RAL 9016; for adjustable ceiling mounting, consisting of 2 U-rails for fixing on the ceiling, 4 threaded rods M8 x 500 mm with bolts, 2 telescopic rails and 2 screw covers</p> <p>1 for Vario Door air curtains</p> <p>5 for horizontal models</p> <p>6 for vertical models</p> <p>Article group 1.51, Manufacturer Kampmann, Article no. 15100010089_ , Type 10089_</p>	required per door air curtain basic unit	
pc.	151 000 1 10 8 25	<p>Replacement filter mat for insertion in door air curtain basic units, filter class G2; Article group 1.51, Manufacturer Kampmann, Article no. 1510001 __ 825, Type 1 __ 825</p>		
pc.	151 000 1 10 8 30	<p>Air inlet grille with frame and filter fixing for installation in suspended ceiling or bespoke casing; inlet grille as linear grille, manufactured from air stream-enhancing aluminium droplet profiles for simple removal of the filter; steel metal frame and inlet grille, fully-powdercoated traffic white RAL 9016; Article group 1.51, Manufacturer Kampmann, Article no. 1510001 __ 830, Type 1 __ 830</p>		
pc.	151 000 1 10 8 20	<p>Replacement filter mat for positioning in air inlet grille; filter class G2; Article group 1.51, Manufacturer Kampmann, Article no. 1510001 __ 820, Type 1 __ 820</p>		
pc.	151 000 1 10 8 40	<p>Outlet air rectifier with steel metal frame for installation in suspended ceilings or bespoke casing; air displacement grille for low-turbulence air flow, adjustable; fully-powdercoated traffic white RAL 9016; Article group 1.51, Manufacturer Kampmann, Article no. 1510001 __ 840, Type 1 __ 840</p>		
pc.	151 000 1 10 8 50	<p>Induction air angle 90° Article group 1.51, Manufacturer Kampmann, Article no. 1510001 __ 850, Type 1 __ 850</p>		
pc.	151 000 1 10 8 60	<p>Flexible connection for air inlet Article group 1.51, Manufacturer Kampmann, Article no. 1510001 __ 860, Type 1 __ 860</p>		
pc.	151 000 1 10 8 70	<p>Flexible connection for air outlet Article group 1.51, Manufacturer Kampmann, Article no. 1510001 __ 870, Type 1 __ 870</p>		
pc.	151 000 1 10 8 80	<p>Air duct for air inlet Length ____ mm Article group 1.51, Manufacturer Kampmann, Article no. 1510001 __ 880, Type 1 __ 880</p>		
pc.	151 000 1 10 8 81	<p>Air duct for air outlet Length ____ mm Article group 1.51, Manufacturer Kampmann, Article no. 1510001 __ 881, Type 1 __ 881</p>		
	Required to complete article no. for DataNorm/EDV	<p>1 for Vario door air curtains</p> <p>10 Model size 10</p> <p>15 Model size 15</p> <p>20 Model size 20</p> <p>25 Model size 25</p>		

Specifications/Ordering

Qty.	Article no.	Description	Price/each	Total price
pc.	196 000 1 0 0 9 1 7	3-Stage switch 0-1-2-3, surface-mounted in a plastic housing, white, Jung Dimensions H x W x D: 82 x 82 x 59 mm Protection class: IP 21; Switching capacity: 10 A Article group 1.96, Manufacturer Kampmann, Article no. 196000100917, Type 100917		
pc.	196 000 1 0 0 9 1 8	3-Stage switch 0-1-2-3, flush-mounted for installation in a 55 mm back-box; cover: white, Jung; Dimensions H x W x D: 82 x 82 x 24 mm Switching capacity: 10 A Article group 1.96, Manufacturer Kampmann, Article no. 196000100918, Type 100918		
pc.	196 000 1 0 0 9 2 0	3-Stage summer/winter switch 0-1-2-3, surface-mounted in a plastic housing, light grey/dark grey; insulated; Dimensions H x W x D: 82 x 82 x 125 mm Protection class: IP 55; Switching capacity: 15 A Article group 1.96, Manufacturer Kampmann, Article no. 196000100920, Type 100920	only for use with thermoelectric shut-off valve type 100910, 100900, 100911	
pc.	196 000 1 0 0 9 2 2	3-Stage summer/winter switch 0-1-2-3, flush-mounted for installation in a 55 mm back-box; cover: white; Dimensions H x W x D: 82 x 82 x 24 mm Switching capacity: 15 A Article group 1.96, Manufacturer Kampmann, Article no. 196000100922, Type 100922	only for use with thermoelectric shut-off valve type 100910, 100900, 100911	
pc.	196 000 1 0 0 9 2 5	5-Stage switch 0-1-2-3-4-5, surface-mounted in a plastic housing, light grey/dark grey; insulated Dimensions H x W x D: 82 x 82 x 125 mm Protection class: IP 55; Switching capacity: 15 A Article group 1.96, Manufacturer Kampmann, Article no. 196000100925, Type 100925		
pc.	196 000 1 0 0 9 2 6	5-Stage switch 0-1-2-3-4-5, flush-mounted for installation in a 55 mm back-box; cover: white Dimensions H x W x D: 82 x 82 x 24 mm Switching capacity: 15 A Article group 1.96, Manufacturer Kampmann, Article no. 196000100926, Type 100926		
pc.	196 000 1 0 0 9 2 8	5-Stage summer/winter switch 0-1-2-3-4-5, surface-mounted in a plastic housing, light grey/dark grey; insulated Dimensions: H x W x D: 82 x 82 x 125 mm Protection class: IP 55; Switching capacity: 15 A Article group 1.96, Manufacturer Kampmann, Article no. 196000100928, Type 100928	only for use with thermoelectric shut-off valve type 100910, 100900, 100911	
pc.	196 000 1 0 0 9 2 9	5-Stage summer/winter switch 0-1-2-3-4-5, flush-mounted for installation in a 55 mm back-box Cover: white Dimensions: H x W x D: 82 x 82 x 24 mm Switching capacity: 15 A Article group 1.96, Manufacturer Kampmann, Article no. 196000100929, Type 100929	only for use with thermoelectric shut-off valve type 100910, 100900, 100911	
pc.	196 000 1 0 0 9 0 6	Cascade module, surface-mounted, in a plastic housing, light grey; for the parallel operation of Vario and Tandem door air curtains; Dimensions: W x H x D: 179 x 255 x 72 mm; Protection class: IP 65 Article group 1.96, Manufacturer Kampmann, Article no. 196000100906, Type 100906		
pc.	196 000 1 0 0 9 1 0	Thermoelectric shut-off valve, 3/4" as an angled valve body with screw connection and thermoelectric actuator 230 V/50 Hz; for Vario door air curtains and Tandem 385 door air curtains, horizontal model Article group 1.96, Manufacturer Kampmann, Article no. 196000100910, Type 100910	only for use with switch type 100920, 100922, 100928, 100929	
pc.	196 000 1 0 0 9 0 0 required to complete article no. for DataNorm/EDV	Thermoelectric shut-off valve, 3/4" as a straight valve body with screw connection and thermoelectric actuator 230 V/50 Hz; for Vario door air curtains and Tandem 385 door air curtains, vertical model Article group 1.96, Manufacturer Kampmann, Article no. 196000100900, Type 100900	only for use with switch type 100920, 100922, 100928, 100929	

Qty.	Article no.	Description	Price/each	Total price
pc.	196 000 1 0 0 9 1 1	Thermoelectric shut-off valve, 1" as a straight valve body with a screw connection and thermoelectric actuator 230 V/50 Hz; for Vario door air curtains, standing models; Article group 1.96, Manufacturer Kampmann, Article no. 196000100911, Type 100911	only for use with switch type 100920, 100922, 100928, 100929	
pc.	196 000 1 0 0 9 6 5	Leaving air temperature limiting valve 3/4" as an angled valve body with thermostatic head and remote sensor, with 2 m capillary tube, including fixing material for mounting the sensor in the air stream; temperature setting range: 20 - 50 °C; for horizontal Vario door air curtain and Tandem 385 door air curtain models; Article group 1.96, Manufacturer Kampmann, Article no. 196000100965, Type 100965		
pc.	196 000 1 0 0 9 6 0	Leaving air temperature limiting valve 3/4" as a straight valve body with thermostatic head and remote sensor, with 2 m capillary tube, including fixing material for mounting the sensor in the air stream; temperature setting range: 20 - 50 °C; for Vario door air curtain vertical models; Article group 1.96, Manufacturer Kampmann, Article no. 196000100960, Type 100960		
pc.	196 000 1 0 0 9 6 6	Leaving air temperature limiting valve 3/4" as a straight valve body with thermostatic head and remote sensor, with 2 m capillary tube, including fixing material for mounting the sensor in the air stream; temperature setting range: 20 - 50 °C; for Vario door air curtain standing models; Article group 1.96, Manufacturer Kampmann, Article no. 196000100966, Type 100966		
pc.	196 000 0 3 0 2 6 8	Frost protection thermostat, supplied separately to switch off fan motors and open the thermoelectric shut-off valve in case of frost, temperature range -10/+12 °C, 3 m capillary tube, with sensor stand-alone monitoring; supplied separately; switching capacity 8 A; Manufacturer Kampmann, Article no. 196000030268, Type 030268	Frost protection thermostat is only required when door air curtains are installed in unheated rooms	
pc.	151 000 ___*___-F	Frost protection thermostat, factory-fitted to switch off fan motors and open the thermoelectric shut-off valve in case of frost, temperature range -10/+12 °C, 3 m capillary tube, with sensor stand-alone monitoring; fitted to door air curtain; switching capacity 8 A; Article group 1.51, Manufacturer Kampmann, Article no. 151000___*___-F, Type ___*___-F		
pc.	151 000 ___*___-00W	Radio remote controller, factory-fitted with operating unit for wall mounting, 3-stage speed control, summer/winter switch; control circuit board and aerial; Article group 1.51, Manufacturer Kampmann, Article no. 151000___*___-00W, Type ___*___-00W	not suitable for use with KaBUS ECO	
	required to complete article no. for DataNorm/EDV			

*Insert door air curtain basic unit type no.

Qty.	Article no.	Description	Price/each	Total price
pc.	196 000 031026	<p>KaBUS ECO Operating unit controls the system providing the means for controlling fan stage, increasing fan speed, room temperature setpoints, fan run-on time, summer/winter operation; the operating mode is displayed by an integral operating LED.</p> <ul style="list-style-type: none"> - Room temperature setpoint 5 bis 25 °C - Switching differential +/- 0,8 K - Fan run-on time without room temperature control, 0 to 10 min adjustable - Fan run-on time with room temperature control, 2 min fixed - Digital input with external activation, e.g. time switch <p>surface-mounted in a plastic housing, white Dimensions: W x H x D: 70 x 70 x 26 mm Protection class: IP 30 Protection class III: safety low voltage Article group 1.96, Manufacturer Kampmann, Articl no. 19600031026, Type 031026</p>		Not for use with door air curtains with remote radio controller, Type ____*____-00W
pc.	151 000 ____*____-00B	<p>KaBUS ECO Power module The KaBUS ECO power module is factory-fitted to the door air curtain and serves to control the valve and the 4-stage fan group. The different operating programmes are selected by a DIP switch integrated within the power module.</p> <p>Voltage 230 V AC/50 Hz</p> <ul style="list-style-type: none"> - Four fan outputs 230 V AC/50 Hz/10 A inductive - Valve output 230 V AC/50 Hz/3 A inductive - Operation/Fault output 24 V DC/30 mA - Frost alert digital input - Digital input for door contact, movement alert etc; - Steel metal housing - Protection class: IP 20 <p>Dimensions: W x H x D: 207 x 185 x 75 mm Article group 1.51, Manufacturer Kampmann, Article no. 151000____*____-00B, Type ____*____-00B</p>		Not for use with door air curtains with remote radio controller, Type ____*____-00W
pc.	196 000 031056	<p>Room temperature sensor surface-mounted, in a plastic housing, white Dimensions: W x H x D: 70 x 70 x 26 mm Protection class: IP 20 Protection class III: safety low voltage Article group 1.96, Manufacturer Kampmann, Article no. 196000031056, Type 031056</p>		
pc.	196 000 031057	<p>Industrial room sensor surface-mounted, in a plastic housing, grey Dimensions: W x H x D: 50 x 50 x 35 mm Protection class: IP 54 Protection class III: safety low voltage Article group 1.96, Manufacturer Kampmann, Article no. 196000031057, Type 031057</p>		
pc.	151 000 ____*____-FOB	<p>Frost protection thermostat and KaBUS ECO power module, factory-fitted Article group 1.51, Manufacturer Kampmann, Article no. 151000____*____-FOB, Type ____*____-FOB</p>		
pc.	151 000 ____*____-FOW	<p>Frost protection thermostat and remote radio controller, factory-fitted Article group 1.51, Manufacturer Kampmann, Article no. 151000____*____-FOW, Type ____*____-FOW</p>		
	Required to complete article no. for DataNorm/EDV			

*insert door air curtain basic unit type no.

Vario Door air curtains for use with cold stores

Qty.	Article no.	Description	Price/each	Total price																																			
pc.	151 000 1 10 335	<p>Vario Door air curtain for use with cold stores, basic unit without heat exchanger; basic construction of sendzimir galvanised steel metal with sound and heat insulation around the fan; air inlet through easily-removable, large filter, filter class G 2; with large radial fans for cold air stream, air intake on both sides and direct-driven, 5-stage switchable via transformers, voltage 230 V/50 Hz; internal motor protection via thermal contacts, motor protection class IP 44, insulation class F</p> <p>_____335 Horizontal model without heat exchanger</p> <p>_____10 Dimensions of Vario door air curtain for use with cold stores (incl. casing) Model size 10: horizontal model L x H x D: 1000 x 260 x 650 mm _____15 Model size 15: horizontal model L x H x D: 1500 x 260 x 650 mm _____20 Model size 20: horizontal model L x H x D: 2000 x 260 x 650 mm _____25 Model size 25: horizontal model L x H x D: 2500 x 260 x 650 mm</p> <p>Technical data</p> <table border="0"> <tr> <td>Switching stage</td> <td>5</td> <td>4</td> <td>3</td> <td>2</td> <td>1</td> <td></td> </tr> <tr> <td>Air volume</td> <td>_____</td> <td>_____</td> <td>_____</td> <td>_____</td> <td>_____</td> <td>m³/h</td> </tr> <tr> <td>Power consumption</td> <td>_____</td> <td>_____</td> <td>_____</td> <td>_____</td> <td>_____</td> <td>W</td> </tr> <tr> <td>Sound pressure level</td> <td>_____</td> <td>_____</td> <td>_____</td> <td>_____</td> <td>_____</td> <td>dB(A)</td> </tr> <tr> <td>Weight</td> <td>_____</td> <td>_____</td> <td>_____</td> <td>_____</td> <td>_____</td> <td>kg</td> </tr> </table> <p>Article group 1.51, Manufacturer Kampmann, Article no. 1510001__335, Type 1__335</p>	Switching stage	5	4	3	2	1		Air volume	_____	_____	_____	_____	_____	m ³ /h	Power consumption	_____	_____	_____	_____	_____	W	Sound pressure level	_____	_____	_____	_____	_____	dB(A)	Weight	_____	_____	_____	_____	_____	kg	Basic unit casings and casing extensions see p 38	
Switching stage	5	4	3	2	1																																		
Air volume	_____	_____	_____	_____	_____	m ³ /h																																	
Power consumption	_____	_____	_____	_____	_____	W																																	
Sound pressure level	_____	_____	_____	_____	_____	dB(A)																																	
Weight	_____	_____	_____	_____	_____	kg																																	
	Required to complete article no. for DataNorm/EDV																																						

Specifications/Ordering

A large rectangular area filled with a fine grid pattern, intended for technical specifications or notes. The grid is composed of small squares and covers most of the page's content area.

Specifications/Ordering

151 0001

Article no.
Vario door air curtain basic unit

Article group
1.51
Vario door air curtain

Installation design
330 horizontal
331 vertical
332 standing (side air stream)

Dimensions incl. casing (L x H x D)
 10 = Mod.1 0, horiz., 1000 x 260 x 650 mm
 vert., 1000 x 650 x 260 mm
 15 = Mod. 15, horiz., 1500 x 260 x 650 mm
 vert., 1500 x 650 x 260 mm
 20 = Mod. 20, horiz., 2000 x 260 x 650 mm
 vert., 2000 x 650 x 260 mm
 stand., 650 x 2000 x 260 mm
 25 = Mod. 25, horiz., 2500 x 260 x 650 mm
 vert., 2500 x 650 x 260 mm
 stand., 650 x 2500 x 260 mm
 30 = Mod. 30, stand., 650 x 3000 x 260 mm
 35 = Mod. 35, stand., 650 x 3500 x 260 mm

151 0001

Article no.
Vario door air curtain casing

Art. group
1.51
Vario door air curtain

Installation design
800 horizontal
801 vertical
802 standing (side air stream)

Dimensions incl. casing (L x H x D)
 10 = Mod.1 0, horiz., 1000 x 260 x 650 mm
 vert., 1000 x 650 x 260 mm
 15 = Mod. 15, horiz., 1500 x 260 x 650 mm
 vert., 1500 x 650 x 260 mm
 20 = Mod. 20, horiz., 2000 x 260 x 650 mm
 vert., 2000 x 650 x 260 mm
 stand., 650 x 2000 x 260 mm
 25 = Mod. 25, horiz., 2500 x 260 x 650 mm
 vert., 2500 x 650 x 260 mm
 stand., 650 x 2500 x 260 mm
 30 = Mod. 30, stand., 650 x 3000 x 260 mm
 35 = Mod. 35, stand., 650 x 3500 x 260 mm

Please state article numbers with your order!

Pos.	Qty.	Article number	Description	Price (see HKL Pricelist)
1		-----		
2		-----		
3		-----		
4		-----		
5		-----		
6		-----		
7		-----		
8		-----		
9		-----		
10		-----		
11		-----		
12		-----		
13		-----		
14		-----		

Specifications / Ordering

National

KAMPMANN GmbH • Friedrich-Ebert-Straße 128-130 • 49811 Lingen (Ems)
Tel. +49 591 7108-0 • Fax +49 591 7108-300 • www.kampmann.de • info@kampmann.de

KAMPMANN GmbH Niederlassung Nord und Mitte 1 Friedrich-Ebert-Straße 128-130 49811 Lingen (Ems)	Tel. +49 591 7108-0 Fax +49 591 7108-300		KAMPMANN GmbH Niederlassung Ost Johann-Gutenberg-Platz 1 06773 Gräfenhainichen	Tel. +49 34953 31-3 Fax +49 34953 31-494
KAMPMANN GmbH Niederlassung Mitte 2 Altenberger-Dom-Straße 113 51467 Bergisch Gladbach	Tel. +49 2202 98892-0 Fax +49 2202 98892-16		KAMPMANN GmbH Niederlassung Süd 1 Liebigstraße 13 97080 Würzburg	Tel. +49 931 98087-0 Fax +49 931 98087-16
KAMPMANN GmbH Niederlassung Berlin Hauptstraße 132 16547 Birkenwerder	Tel. +49 3303 5375-0 Fax +49 3303 5375-16		KAMPMANN GmbH Niederlassung Süd 2 Bahnhofstraße 1 82216 Maisach	Tel. +49 8141 3991-0 Fax +49 8141 3991-16



International

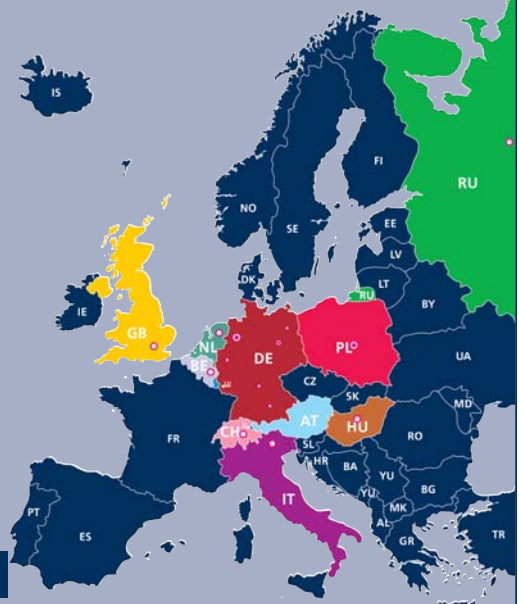

AT	KAMPMANN GmbH Austria Office Bahnhofstraße 1 82216 Maisach – Germany	Tel. +49 8141 3991-0 Fax +49 8141 3991-16 www.kampmann.at	IT	KAMPMANN GmbH Italy Office Tecnoprisma S.R.L. Via del Vigneto, 19 Il piano 39100 Bolzano	Tel. +39 0471 930158 Fax +39 0471 513078 www.kampmann.it
BE	KAMPMANN GmbH Belgium Office Godsheidestraat 1 3600 Genk	Tel. +32 11 378467 Fax +32 11 378468 www.kampmann.be	LU	KAMPMANN GmbH Luxemburg Office Godsheidestraat 1 3600 Genk – Belgium	Tel. +32 11 378467 Fax +32 11 378468 www.kampmann.be
CH	KAMPMANN GmbH Repräsentanz Schweiz Tödisstraße 60 8002 Zürich	Tel. +41 44 2836-185 Fax +41 44 2836-186 www.kampmann.ch	NL	KAMPMANN GmbH Netherlands Office Boeierstraat 10 A 8102 HS Raalte	Tel. +31 572 393214 Fax +31 572 382048 www.kampmann.nl
CN	KAMPMANN (Beijing) Co., Ltd. 1102, Block A, Gateway Plaza No. 18, Xia Guang Li, North Road, Chaoyang District 100027 Beijing	Tel. +86 10 59231278 Fax +86 10 59231248 www.kampmann.cn	PL	KAMPMANN Polska Sp. z o. o. ul. Lotnicza 21f 99-100 Łęczycza	Tel. +48 24 7219100 Fax +48 24 7219190 www.kampmann.pl
GB	KAMPMANN GmbH UK Office Dial House Govett Avenue, Shepperton, Middlesex, TW17 8AG	Tel. +44 1932 228592 Fax +44 1932 228949 www.kampmann-uk.co.uk	PL	KAMPMANN Polska Sp. z o. o. ul. Słowackiego 1 85-008 Bydgoszcz	Tel. +48 52 5836536 Fax +48 52 3406511 www.kampmann.pl
HU	KAMPMANN GmbH Hungary Office 1031 Budapest Órló u. 30	Tel. +36 1 2426830 Fax +36 1 4532416 www.kampmann.hu	RU	KAMPMANN GmbH Representative Office Moscow ul. 4 Magistralnaya, dom 11, stroenie 2 123007 Moscow	Tel. +7 495 3630244 Fax +7 495 3630244 www.kampmann-rus.ru

all other
countries

KAMPMANN GmbH • Friedrich-Ebert-Straße 128-130 • 49811 Lingen (Ems) – Germany
Tel. +49 591 7108-660 • Fax +49 591 7108-173 • www.kampmann.de



Product information

- Stainless steel with brushed surface for lasting class
- Alternative powdercoating
- Enhanced sound attenuation coatings meet higher sound conditions
- Top air discharge prevents swirling dust
- Summer mode without hot water supply provides back-up for air conditioning systems
- Winter mode utilises roof-level accumulated heat to provide air screening

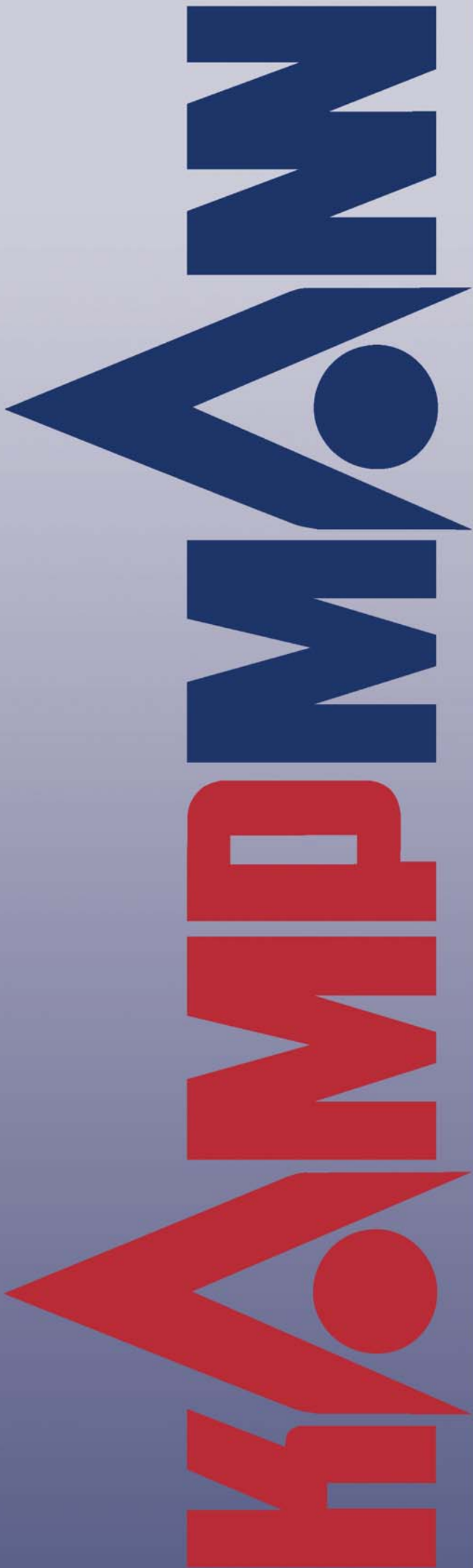

KAMPMANN GmbH

UK Office

Dial House

Govett Avenue • Shepperton, Middlesex TW17 8AG

Tel. +44 1932 228592 • Fax +44 1932 228949

info@kampmann-uk.co.uk • www.kampmann-uk.co.uk

Keane Environmental Ltd

Kilkenny Office • Kilcross • Inistioge • Co. Kilkenny

Tel. +353 56 7758524 • Fax +353 56 7758737

keaneenv@iol.ie • www.kampmann.de



SYSTEMS FOR HEATING • COOLING • VENTILATING

KAMPMANN GMBH • Germany

Friedrich-Ebert-Straße 128 - 130 • 49811 Lingen (Ems)

Telefon: +49 591 7108-0 • Telefax +49 591 7108-300

info@kampmann.de • www.kampmann.de